

LA-UR- 2096

Title: Accelerator-Based Conversion (ABC) of Weapons
Plutonium: Plant Layout Study and Related Design Issues

Author(s): B. S. Cowell, R. A. Krakowski, C. A. Beard, J. J. Bukna,
J. W. Davidson, M. H. Fontana, C. Sailor, M. A. Williams

Submitted to: General Distribution



Los Alamos
NATIONAL LABORATORY

Los Alamos National Laboratory, an affirmative action/equal opportunity employer, is operated by the University of California for the U.S. Department of Energy under contract W-7405-ENG-36. By acceptance of this article, the publisher recognizes that the U.S. Government retains a nonexclusive, royalty-free license to publish or reproduce the published form of this contribution, or to allow others to do so, for U.S. Government purposes. The Los Alamos National Laboratory requests that the publisher identify this article as work performed under the auspices of the U.S. Department of Energy.

DISTRIBUTION OF THIS DOCUMENT IS UNLIMITED

MASTER

Form No. 836 Rev. 87 8/89 1091

**ACCELERATOR-BASED CONVERSION
(ABC) OF WEAPONS PLUTONIUM:
PLANT LAYOUT STUDY AND
RELATED DESIGN ISSUES**

**B. S. Cowell*, R. A. Krakowski, C. A. Beard, J. J. Buksa,
J. W. Davidson, M. H. Fontana*, W. C. Sailor, M. A. Williamson**

*** Oak Ridge National Laboratory**

word processing and compilation

by

Kay Grady

ACCELERATOR-BASED CONVERSION (ABC) OF WEAPONS PLUTONIUM: PLANT LAYOUT STUDY AND RELATED DESIGN ISSUES

by

B. S. Cowell*, R. A. Krakowski, C. A. Beard, J. J. Buksa,
J. W. Davidson, M. H. Fontana*, W. C. Sailor, M. A. Williamson

* Oak Ridge National Laboratory

ABSTRACT

In preparation for and in support of a detailed R&D Plan for the Accelerator-Based Conversion (ABC) of weapons plutonium, an ABC Plant Layout Study was conducted at the level of a pre-conceptual engineering design. The plant layout is based on an adaptation of the Molten-Salt Breeder Reactor (MSBR) detailed conceptual design that was completed in the early 1970s. Although the ABC Plant Layout Study included the Accelerator Equipment as an essential element, the engineering assessment focused primarily on the Target; Primary System (blanket and all systems containing plutonium-bearing fuel salt); the Heat-Removal System (secondary-coolant-salt and supercritical-steam systems); Chemical Processing; Operation and Maintenance; Containment and Safety; and Instrumentation and Control systems. Although constrained primarily to a reflection of an accelerator-driven (subcritical) variant of MSBR system, unique features and added flexibilities of the ABC suggest improved or alternative approaches to each of the above-listed subsystems; these, along with the key technical issues in need of resolution through a detailed R&D plan for ABC are described on the bases of the "strawman" or "point-of-departure" plant layout that resulted from this study.

DISCLAIMER

This report was prepared as an account of work sponsored by an agency of the United States Government. Neither the United States Government nor any agency thereof, nor any of their employees, makes any warranty, express or implied, or assumes any legal liability or responsibility for the accuracy, completeness, or usefulness of any information, apparatus, product, or process disclosed, or represents that its use would not infringe privately owned rights. Reference herein to any specific commercial product, process, or service by trade name, trademark, manufacturer, or otherwise does not necessarily constitute or imply its endorsement, recommendation, or favoring by the United States Government or any agency thereof. The views and opinions of authors expressed herein do not necessarily state or reflect those of the United States Government or any agency thereof.

TABLE OF CONTENTS

I. EXECUTIVE SUMMARY

II. INTRODUCTION

- A. Background
- B. Scope and Approach
- C. Concept Description
 - 1. Molten-Salt Breeder Reactor (MSBR)
 - 2. Accelerator-Based Conversion (ABC)
- D. Design Ground Rules
 - 1. Goal Disposition Capacity
 - 2. Top-Level ABC Design Options and Basecase Focus

III. ABC BASECASE PLANT LAYOUT

- A. Overview of Basecase Layout
- B. Main Subsystem Descriptions
 - 1. Accelerator (ACC)
 - a. Overview
 - b. Target Interface
 - 2. Target (TAR)
 - a. Overview
 - b. Specific Design Issues
 - 3. Primary System
 - a. Core
 - b. Fuel-Salt Pump
 - c. Intermediate Heat Exchanger
 - d. Reactor Vessel and Primary System Piping
 - 4. Heat-Removal System
 - a. Secondary Coolant System
 - b. Steam Generator
 - c. Steam Reheater
 - d. Supercritical Steam System
 - 5. Chemical Processing
 - a. Fuel-Salt Preparation
 - b. Drain Tank
 - c. Off-Gas Handling
 - d. On-Line Separations
 - e. End-of-Life Separations
 - 6. Operations and Maintenance
 - a. Target
 - b. Blanket
 - c. Other Primary System Components
 - 7. Containment and Safety
 - 8. Instrumentation and Control

IV. KEY ISSUES

A. Overview and Design Departures from MSBR

B. Main Subsystems

1. Accelerator
2. Target
3. Primary System
 - a. Core
 - b. Fuel-Salt Pump
 - c. Intermediate Heat Exchanger
4. Heat-Removal (Secondary) Systems
 - a. Secondary Coolant Salt
 - b. Supercritical Steam System
5. Chemical Processing
6. Operations and Maintenance
7. Instrumentation and Control
8. Containment and Safety

V. CONCLUSIONS AND RECOMMENDATIONS

A. Ordering of Key Issues

1. Materials and Fuel-Salt Chemistry
2. Main ABC Subsystems
 - a. Target
 - b. Blanket
 - c. Chemical Processing
 - d. Primary Systems
 - e. Secondary and Balance-of-Plant Systems
 - f. Containment and Safety

B. Alternative Design Approaches

1. Target-Blanket
2. Primary Coolant Systems
3. Secondary Coolant System
4. Chemical Processing
5. Power-Conversion System

REFERENCES

NOMENCLATURE

FIGURES

TABLES

Appendix A. Subsystem Design Bases and Equipment Scaling

- A.1. Introduction
- A.2. Background
- A.3. Assumptions
- A.4. Individual System Descriptions
 - A.4.1. Accelerator
 - A.4.2. Target
 - A.4.3. Primary System

- A.4.3.1. Core
- A.4.3.2. Fuel-Salt Pump
- A.4.3.3. Intermediate Heat Exchanger
- A.4.3.4. Fuel-Salt Piping
- A.4.4. Balance of Plant
 - A.4.4.1. Coolant-Salt System
 - A.4.4.2. Steam Generator
 - A.4.4.3. Steam Reheater
 - A.4.4.4. Coolant-Salt Piping
 - A.4.4.5. Power-Conversion Equipment
 - A.4.4.6. Steam System Piping
- A.4.5. Chemical Processing
 - A.4.5.1. Salt Cleanup Systems
 - A.4.5.2. Fuel Salt Drain Tank
 - A.4.5.3. Off-gas Processing System
- A.4.6. Instrumentation and Control
- A.4.7. Operation and Maintenance
- A.4.8. Safety Systems
- A.5. Flow Calculations
 - A.5.1. Fuel Salt
 - A.5.2. Coolant Salt
- A.6. Outstanding Issues for the Reference Steam Design
 - A.6.1. Materials
 - A.6.1.1. Fuel Salt
 - A.6.1.2. Secondary Coolant
 - A.6.1.3. Haselloy-N
 - A.6.1.4. Graphite
 - A.6.2. Engineering Design
 - A.6.2.1. Core
 - A.6.2.2. Intermediate Heat Exchangers
 - A.6.2.3. Molten-Salt Circulation Pumps
 - A.6.2.4. Drain Tank
 - A.6.2.5. Fuel-Salt Drain Valve
 - A.6.2.6. Bubble Generator and Separator
 - A.6.2.7. Off-gas System
 - A.6.2.8. Steam Generators
 - A.6.2.9. Instrumentation and Control
 - A.6.2.10. Cell Wall Construction
 - A.6.3. Other Outstanding Issues
 - A.6.3.1. Tritium
 - A.6.3.2. Chemical Processing
 - A.6.3.3. Fission-Product Distribution
 - A.6.3.4. Steam Conditions
 - A.6.3.5. Maintenance
 - A.6.3.6. Safety Analyses

Appendix B. Accelerator Scaling Relationships for ABC.

Appendix C. Accelerator-Based Conversion (ABC) Spallation Target: Function and Design Issues.

- C.1. Target Function**
- C.2. Target Design Issues**
 - C.2.1. Target Material**
 - C.2.2. Target Geometry**
 - C.2.3. Target Heat Removal**
- C.3. Selection of Target Material**
- C.4. Physics Optimization**
- C.5. Target Waste Generation**
- C.6. Conclusions**

Appendix D. Directly Cooled Target *versus* Separately Cooled Window.

Appendix E. Constant- k_{eff} Fuel-Cycle and dpa Analyses for the Plutonium-Burning ABC Concept Based on the Graphite-Moderated Molten-Salt Blanket

- E.1. Introduction**
- E.2. Model**
- E.3. Results**
 - E.3.1. Case Without Graphite Moderation**
 - E.3.2. Target/Blanket Depletion Calculations for ABC**
- E.4. Conclusions**

Appendix F. Sizing of Beam Bending and Expansion Configuration.

I. EXECUTIVE SUMMARY

Accelerator-Based Conversion (ABC) of commercial and weapons plutonium to short-term radioactive waste and net electrical energy proposes to exploit unique benefits and technical discriminators that evolve from the joining of driven (subcritical) nuclear operation with a low-inventory, fluid-fuel system. As part of an ongoing and broadening technical assessment of technical merits, an ABC Plant Layout Study was initiated to develop an early appreciation for size, inventory, operational, maintenance, safety, and general interfacial issues.

Since the molten-salt-based ABC approach is only in the earliest conceptual stage of development, this ABC Plant Layout Study relied heavily on the detailed conceptual engineering design of the Molten-Salt Breeder Reactor (MSBR) completed by the Oak Ridge National Laboratory in the early 1970s. Scaling from the MSBR design, a quantitative layout of a single (711 MWt) Target/Blanket unit for the molten-salt ABC is reported; four of these Target/ Blanket units would be driven by a single accelerator; and three such 2,844-MWt [1,263 MWe(gross); 1,074 MWe(net)] ABC systems would be required to dispose of ~50 tonne of weapons plutonium in 20 years for an average plant availability of 75%. The scaling of all key components from spallation target → primary systems (blanket and primary coolant) → secondary-coolant systems → balance of plant, including important elements of the chemical-processing system, are reported. On the basis of this scaling, the ratio of fuel salt in the blanket to that in the entire system is 0.34; the total fuel-salt power density (including exo-blanket inventory) is 57. MWt/m³; and the ratio of containment volume to thermal power is 32.m³/MW.

Key technical issues that have been defined in the course of this ABC Plant Layout Study are summarized, as they relate to: target-blanket longevity from both radiation-damage and chemical-corrosion view points; molten-salt chemistry issues ranging from time-varying plutonium-fuel solubilities to structural attack by soluble fission products; the (vertical) Target/Blanket maintenance scheme; the use of sodium fluoroborate secondary-coolant salt *versus* other secondary coolant options; cost (*e.g.*, high pressure) *versus* benefit (*e.g.*, high thermal-to-electric conversion efficiency) of the supercritical-steam cycle adopted from the MSBR design; the feasibility of the chemical separations for noble-gas, noble-metal, and soluble fission products that form the basis of the chemical-processing scheme adopted; the in blanket and exo-blanket disposition of gaseous, noble-metal, and soluble lanthanides waste streams and the magnitude of these waste streams when used target-blanket materials are included; and general containment and safety considerations related to the fluid-fuel system adopted. These issues are quantitatively identified in the context of the ABC Plant Layout Study for elaboration by an ongoing, parallel ABC R&D planning activity.

While the main goal of the ABC Plant Layout Study is to provide early input to the ABC R&D Plan, the main goal of this report, in addition to listing all major non-accelerator engineering issues for the ABC R&D Plan, is to summarize: a) the characteristics of a basecase ABC "strawman" design; b) key scoping calculations (target, blanket, beam bending magnets, *etc.*); and c) the groundrules and scaling procedures used to translate the detailed and well-documented MSBR conceptual design into the context of ABC. The latter two contributions are of particular importance to the generation of a self-consistent ABC conceptual design (an associated cost estimates) in the future, and for these reasons the

groundrules, MSBR → ABC engineering scaling relationships, and ancillary support computations have been thoroughly documented in appendices to this report.

A number of key technical and operational issues have been identified in the course of conducting this ABC Plant Layout Study. Running as a common thread through all these technical issues are materials concerns related to component longevity in a highly corrosive and high-radiation environment. These material issues impact all operational, safety, economic, and environmental projections for ABC. While the comprehensive, but somewhat aged, MSBR "data base" has been used extensively in the selection of structural materials, nuclear components, and molten-salt compositions, the flexibility offered by the subcritical-driven ABC approach opens possibilities not available to MSBR; unfortunately, little or no experience beyond that provided by the MSBR project is available. Recognizing this common materials thread and related database limitations, key technical issues identified by the ABC Plant Layout Study are summarized below according to the main ABC subsystem; elaborations of these points are found in the main body of the report and the appendices.

- Accelerator Equipment:

- all physics and engineering requirements needed to assure $\geq 75\%$ availability for a 800-1,000 MeV, 50-100 MW (beam) proton Linac that is multiplexed with four independent Target-Blanket and Balance-of-Plant systems that in effect comprise four independent ~300-MWe power stations; these issues were not included in the charter of the ABC Plant Layout Study;
- topology of High-Energy Beam Transport system that linearly in series "kicks off" four beamlets to each of the ~4 ABC power-plant modules;
- beamlet transport, bending, expansion, and "footprint" control upon impinging each Target window after traversing the primary containment building (tertiary containment boundary) where major maintenance operations (on each ABC module) must occur;
- need for fast-acting Beam Tube Isolation Valves (BTIVs) on a system that links directly all three confinement zones [unlike the similar Main Steam Isolation Valves (MSIVs), that connect only the outer containment zone to the environment]; incorporation of the accelerator tunnel/buildings into the three-tiered containment system adopted for ABC would be prohibitively expensive.

- Target:

- availability of containment material with acceptable longevity in a high-temperature (????K), corrosive (flowing liquid lead), intense radiation field (???? $\times 10^{20}$ n/m²/s high-energy neutrons) environment;
- thermal uniformity and effectiveness of the self-cooled, integrated window that separates the Target-Blanket from the high-energy proton-beam line and Accelerator Equipment vacuum system;
- maintenance configuration (vertically into Containment Building) and separability from molten-salt/graphite/Hastelloy-N blanket; thermal insulation between Target and Blanket systems to control heat leakage (to Target coolant system);
- choice and configuration of Target coolant system; choice between rejection of target power (including blanket thermal in-leakage) as low-grade heat *versus* recovery by thermal-conversion cycle for addition to gross-electric output.

- **Primary System:**
 - **Core:**
 - configurational choice (MSBR-like homogeneity *versus* fully reflected) as related to component (moderator, moderator/reflector, internal structure, reactor vessel) longevity in a high neutron flux ($????\times 10^{20}$ n/m²/s);
 - fuel-salt/fission-product/plutonium interactions with graphite and extent of post-irradiation cleanup needed to assure minimum waste stream that can be classified as Low Level Waste;
 - maintenance configuration (vertically into Containment Building) and relative separability of reactor vessel from other Primary System components (pumps, fuel-salt dump tank, IHXs).
 - **Fuel-Salt Pump:**
 - straight-forward pump design, but no operating experience with pumps of capacity required by ABC;
 - efficacy of the pump (bowl) as a major element in the Chemical- Processing system (fission-product off-gas release from fuel salt) and volume of fuel-salt inventory in pump bowl;
 - length of drive shaft (??? m) needed to provide adequate distance between highly radioactive fuel salt and the radiation-sensitive pump motor, from both mechanical and maintenance viewpoints.
 - **Intermediate Heat Exchanger (IHX):**
 - feasibility of and need for the unique U-tube/U-shell configuration adopted from MSBR, that efficiently minimized fuel-salt volume but may present a non-optimal maintenance geometry for ABC;
 - deposition of noble-metal (relative to fluorine) fission products onto cooler surfaces of IHX, and opportunity to convert a potential problem into an option for that component of the Chemical-Processing system;
 - possible need to provide a tritium diffusion barrier to prevent tritium migration into the secondary coolant-salt system and beyond;
 - control of tube leaks and secondary-coolant-salt egress into the fuel salt.
 - **Fuel-Salt Piping:**
 - optimum pipe sizes and pipe runs that minimize further the exo-blanket fuel-salt inventory while assuring acceptable flow velocities in a configuration that optimizes an otherwise messy component-maintenance operation;
 - deposition and accumulation of noble-metal fission products.
- **Balance of Plant (BOP):**
 - **Secondary-Coolant-Salt System:**
 - Intermediate Heat Exchanger: same as discussed above under the Primary System;
 - Secondary-Coolant-Salt Pump: design similar to fuel-salt pump, except for need to purge pump bowl of gaseous fission products; an added complication related to SG/SR flow metering, as listed below, is identified, however.
 - Steam Generator (SG):
 - * feasibility of and need for the unique U-tube/U-shell configuration adopted from MSBR;
 - * design and operation of high-pressure (25.8 MPa, 810 K) supercritical-steam (SCS) cycle, and impact of steam-tube failure on Secondary-Coolant-Salt-System design (including respective cells)

- * metering of secondary coolant salt to accommodate SG/SR split using variable-speed pump motors *versus* metering valves.
 - **Steam Reheater (SR):**
 - * impact of tube failure and subsequent pressurization of the Secondary-Coolant-Salt System;
 - * concern of freezing secondary coolant salt and need to maintain a minimum feedwater temperature.
- **Power-Conversion Equipment:**
 - **Steam Generator (SG):** as addressed above under Secondary-Coolant-Salt System
 - **Steam System Piping:**
 - * design for SCS system (25.8 MPa, 810 K) and need for thick-walled pipes and long pipe runs;
 - * because of the last requirement, many smaller steam tubes required to deliver steam to the Turbine Plant Equipment, with impact on the number and reliability of MSIVs.
 - **Turbine Plant Equipment:**
 - * economic impact of using low-capacity (316 MWe) turbines;
 - * possible need to locate turbine within a containment building for reasons related to tritium migration and/or the need for multiple MSIVs with reduced ensemble reliability.
 - need to examine operational, design, safety, and cost trade offs associated with higher-efficiency SCS cycle and a less-efficient but simpler Power-Conversion systems.
- **Chemical Processing:**
 - **Off-Gas Processing:**
 - efficacy of helium-gas sparging in the fuel-salt pump bowl to separate gaseous fission products, compared to implementation as a separate unit;
 - efficiency, volumes, stability, and waste streams associated with getter-bed collection on activated charcoal (MSBR) or zeolites;
 - need and means for post-collection separations and re-introduction of specific fission products into Core for subsequent irradiation.
 - **Fuel-Salt Drain Tank:**
 - need for and advisability of the multifarious role of Fuel-Salt Drain Tank *vis-à-vis* Chemical Processing (of nonvolatiles), central collection point, fueling station, standby storage during maintenance of all Primary System components, and safe storage and afterheat removal under loss of (normal) cooling conditions (to name a few);
 - reliability and speed (both opening and flow times) of fuel-salt freeze valve that connects Core with Fuel-Salt Dump Tank;
 - generally "captured" location in reactor-vessel cell and ability to monitor and maintain.
 - **Fuel-Salt Cleanup Systems:**
 - feasibility and means of on-line removal of noble-metal fission products (cold traps, electrowinning, REDOX control, *etc.*)
 - feasibility and means of post-irradiation batchwise cleanup of fuel salt from plutonium and higher actinides (for re-injection into the fuel salt) and soluble fission products (lanthanides);

- degree to which rejected salt can be classified as Low-Level Waste, and degree to which salt recycle can be implemented.
- **Other Cleanup Operations/Systems:**
 - target lead cleanup of spallation and corrosion products;
 - cleanup of Core components (mainly graphite) prior to disposal as (ideally) reduced-volume, Low-Level Waste;
 - cleanup and (ideally) recycle of off-gas getter beds.
- **Instrumentation and Control (I&C):**
 - Accelerator Equipment interface and control with Primary System, Balance-of-Plant, and Safety systems requires a detailed and self-consistent design before the myriad of control issues under both transient (scheduled or unscheduled) and steady-state conditions can be identified and assessed; a similar statement applies to the other I&C categories listed below;
 - nuclear and power control systems operated in conjunction with chemical and mechanical controllers distributed throughout the Primary System;
 - Balance-of-Plant I&C systems dealing with internal operations and safety conditions and responses of each of four power-conversion systems, electrical power distribution within each 316 MWe unit [particularly for Accelerator Equipment power requirements (152 MWe)], and distribution of reliable electrical power to the electrical grid for needed revenue generation;
 - resolution of individual and interactive I&C requirements associate with plant (Primary System) operations, on-site radwaste storage, fuel-salt conditioning and cleanup, and overall waste-stream management.
- **Safety Systems:**
 - increased ABC concept resolution needed to verify the feasibility of a three-tiered confinement philosophy under both operating and maintenance conditions;
 - define better the means of reactivity and power control within each core (fuel-salt composition, control/shutdown rods inserted into the Core, fuel-salt flow rate, *etc.*)
 - improve understanding of multiply-connected equipment cells (*e.g.*, reactor vessel, fuel-salt dump tank, secondary coolant salt, SCS generator, chemical processing, *etc.*) responses to failure of interfacial equipment (*e.g.*, IHXs, SGs, Fuel-Salt Dump Tank, *etc.*);
 - resolve better the multi-functional role of the primary containment building as this structure provides: a) the tertiary containment envelope; b) the systems for the last manipulations/conditioning of the high-energy proton beam; and c) the central volume and laydown area for maintenance of major equipment in the Primary System.

II. INTRODUCTION

A. Background

The use of accelerator-produced neutrons to sustain high burnup of weapons plutonium in a subcritical configuration as been proposed¹⁻³ as a means to dispose of this material^{4,5}. When combined with a fluid-fuel blanket, the driven (subcritical) Accelerator-Based Conversion (ABC) system for the burning of plutonium and the concomitant generation of electrical power offers a number of symbiotic benefits and discriminating characteristics³. As summarized in Table I, these benefits and discriminators that derive from the combination of burning plutonium in a subcritical, fluid-fuel power plant center on the prospects of enhanced nuclear safety in a system that offers: a) significant operational flexibility resulting from a relaxed neutron balance; b) the prospects of a reduced long-lived waste stream, "deep" plutonium burns; c) and a shift of unit operations away from chemical processing towards physical separations. These characteristics combine to promise a safer, cleaner, and more-flexible deep-burn system with reduced far-term population doses. Many of the processes upon which these claims are build, however, remain to be taken beyond the preconceptual level and, along with the need to minimize the capital and operational costs associated with the accelerator-based neutron generator, are recognized a crucial uncertainties in need of resolution.

The ABC approach to dealing with weapons and commercial plutonium has been explored primarily at a conceptual level¹; only relatively unintegrated target, blanket-neutronics⁷, blanket thermal-hydraulics, materials⁶, and chemical-separations⁸ scoping calculations have so far been made. While not sufficient to commence a detailed conceptual design of an ABC, the essential elements of this system are adequately defined to begin a preliminary plant layout, given that key ABC subsystem choices are made and related assumptions can be accepted. Furthermore, the process used to make the choices and assumptions needed to advance a preliminary plant layout provides a strong focus for the development of the ABC concept. This focusing onto and identification of the main technical issues for key ABC subsystems, as well as beginning a more concrete assessment of the benefits and discriminators listed in Table I, is the primary goal and product of this ABC Plant Layout Study. This ABC Plant Layout Study, therefore, serves an important integrating function that can be applied prior to any preconceptual design activity to assure that the unique characteristics of this accelerator-driven, fluid-fuel system are fully exploited while using the best of the ideas developed in conjunction with the detailed MSBR design.

B. Scope and Approach

The main goal of this ABC Plant Layout Study is the generation of a preliminary, but self-consistent, engineering layout of a weapons-plutonium-burning ABC. This plant layout is based on the individual scoping computations of key subsystem elements; some of these scoping calculations are reported in the Appendices to this report. The technical trade offs, options, or choices required to generate this ABC plant layout are collected and prioritized to provide the main issues used to define a long-term R&D plan⁹ for ABC. A basecase set of design assumptions and parameters is needed to perform this preconceptual, plant-layout task. Central to the definition of this base case is the direct adaptation and scaling of the early detailed design of the Molten-Salt Breeder Reactor (MSBR) concept^{10,11}. The more-or-less direct application of the MSBR design to the ABC Plant Layout Study was

made to expedite the engineering layout and the technical issues this layout defines, and not because the MSBR parameters in the context of ABC were necessarily optimal or the best choice(s). While the advantages of the molten-salt fluid fuel for these accelerator-driven systems are well known^{1,2}, the specific MSBR embodiment for ABC applications may not represent the best choice, as will be shown. Never-the-less, use of MSBR experience in generating the ABC base case reported herein has allowed the plant layout and associated technical assessment to proceed on the basis of the substantial, related technical work reported as part of the MSBR conceptual engineering design¹⁰.

Central to obtaining any meaningful result from a pre-conceptual design study of the kind reported here is a clear statement of design ground rules. After a brief description of both the ABC and MSBR concepts in Sec. I.C., these design ground rules are laid out in Sec. II.D. for both the scale of the plutonium disposition task and for the ABC design options and focused base case that form the core of this ABC Plant Layout Study. Section III. reports the ABC plant layout on a subsystem-by-subsystem basis, with the details of the engineering scaling and assumptions used to generate the basecase layout being described in Appendix A. The main technical issues identified in the course of generating the MSBR-based ABC base case are described in Sec. IV. in both general and a subsystem-by-subsystem contexts. After prioritizing these issues (Sec. IV.C.), as well as identifying attractive design alternatives to the MSBR base case (Sec. IV.D.), Sec. V. concludes with a summary of "top-level" R&D requirements for an optimized ABC-based disposition of weapons-grade plutonium; Sec. V. also gives recommendation for optimal technical directions to be taken by any future, more-detailed conceptual engineering design of ABC.

C. Concept Description

Figure 1 gives a systems block diagram of the ABC plant. The ABC is divided into the following four main systems: Accelerator (ACC); the target (TAR) and blanket (BLK), which together form the reactor core and, when combined with the primary pump(s) and intermediate heat exchangers (IHXs), comprise the primary heat-transport (PHT) system; the secondary (coolant-salt) heat-transport (SHT) system; the steam and power-conversion system, which is designated here as the balance-of-plant (BOP); and the chemical plant equipment (CPE) system that is comprised of fuel-loading, off-gas (tritium and volatile fission products) handling, non-volatile fission product (physical and/or chemical separations). When superposed onto a commonly adopted Program of Cost Codes^{12,13} that must be used to evaluate ultimate techno-economic trade offs^{14,15}, and including power and mass flows that characterize an ABC that generates net-electric power, the systems diagram given in Fig. 2 results. In the most aggregated form, the ABC plant consists of Accelerator and Reactor Plant Equipment (A/RPE), Chemical Plant Equipment (CPE), and Balance of Plant (BOP), all situated on and within Structures and Site (SITE) systems. After briefly reviewing the MSBR concept, the resulting marriage with an accelerator-base neutron source to form the ABC concept is described.

1. Molten Salt Breeder Reactor (MSBR)

The essential elements of the ABC nuclear and power-conversion systems used to define the ABC base case have been taken directly or scaled from the MSBR engineering design reported in Ref. 10. This 1,000-MWe(2,250 MWt, 44.4% efficient) power-plant design utilizes four LiF-BeF₂-(Th,U)F₄ primary (fuel-salt) coolant loops, that transferred the fission power to a NaF-NaBF₄ secondary (coolant-salt) loop; the secondary coolant salt in

turn drives an advanced supercritical-steam (SCS) power conversion that relies on strong reheat from the secondary coolant salt to achieve a high thermal-conversion efficiency. Figure 3 is a composite replication of the MSBR coolant(s) and power-conversion systems, and is include here because of its frequent comparative use in the ABC Plant Layout Study. The level of conceptual-design detail available for most of the key subsystems listed on Fig. 3 made the Ref.-10 study particularly valuable as a resource with which to scale the present molten-salt ABC plant layout, despite obvious differences in application, engineering, materials, and neutronics constraints, and driving technologies. Many of these engineering and materials differences reflect the need to accommodate a neutron spallation target and the sub-critical operation of the ABC core, as is summarized in Table I. The shift from use of “chemical separations” in the MSBR to “physical separations” in the ABC design also represents an important deviation. The essential elements of a molten-salt ABC are illustrated in Fig. 4, which gives a “top-level” power- and mass-flow diagram that has been loosely adapted from the MSBR design shown in Fig. 3.

2. Accelerator-Based Conversion (ABC)

As adopted in the MSBR design, the fuel-salt dump tank (Figs. 3 and 4) serves as a focal point for most CPE-related operations, including any slip-stream operations associated with the (preferred) electrowinning (*e.g.*, electrolytic deposition) collection of noble (with respect to fluorine) metal fission products. Figure 4 also indicates of the tertiary confinement approach adopted for both the MSBR conceptual design and the ABC plant layout reported herein. Also shown is a reheat stream taken directly from the secondary coolant-salt stream for possible use in driving a supercritical-steam thermal-to-electric conversion cycle at the high efficiencies projected for the MSBR. Lastly, for the purposes of establishing design ground rules in the definition of the ABC base case, the target window (WIN), operational and maintenance (O&M) systems, and systems related to plant safety (SAF) are identified as organizational units, albeit, some connectivity between these ten ABC systems exists (Sec. II.D.2.).

The thermal and electrical power flows indicated on Figs. 2 and 4 show the conversion of electrical power P_{EA} delivered to the accelerator to beam power P_B with an overall “wall-plug” efficiency of $\eta_A = P_B/P_{EA}$. Upon passing through a window, this beam power is converted (ideally) to fission power, P_F , with a gain $P_F/P_B = \beta k_{eff}/(1 - k_{eff})$, where k_{eff} is the blanket neutron multiplication and $\beta \sim 1.7-1.8$ is the ratio of fission energy per fission neutron, E_F/ν , to beam energy per target neutron, E_B/Y . Typically, the target neutron yield can be approximated by $Y \simeq (E_B - E_B^0)/y$, where the fitting constants are $E_B^0 \simeq 200$ MeV/p and $y \simeq 35$ MeV/n; for $E_F = 200$ MeV/n, $\nu \simeq 2.8$ n/fission, and $E_B \simeq 800$ MeV/p, it follows that $E_F/\nu = 71.4$ MeV/n, $E_B/Y = y/(1 - E_B^0/E_B) \simeq 46.7$ MeV/n, and $\beta = (E_F/\nu)/E_B/Y = 15.3$. Once converted to total or gross electrical power, $P_{ET} = \eta_{TH} P_F$, and after skimming off the accelerator power, P_{EA} , and a small amount of non-accelerator BOP power, $P_{AUX} = \epsilon_{AUX} P_{ET}$, the net power $P_E = P_{ET} - P_{EA} - P_{AUX}$ is delivered to the grid. With the total plant recirculating-power fraction defined as $\epsilon = \epsilon_{AUX} + P_{EA}/P_{ET}$, the net plant efficiency is $\eta_p = \eta_{TH}(1 - \epsilon)$; typically, ϵ is in the range 0.15 - 0.20 for highly multiplying, but still significantly subcritical, blanket assemblies.^{i4,15} Hence, whereas $\eta_p \simeq \eta_{TH} = 0.44$ for the MSBR, the equivalent ABC plant efficiency would be reduced to $\sim 0.34-0.37$.

A direct mapping of the MSBR mass and power flows (Fig. 3) into those expected of the plutonium-burning ABC (Figs. 2 and 4) does not have a one-to-one correspondence, even if approximate size and capacity scalings are available (Appendix A). Differences in fuel-salt compositions [the ABC has no (Th,U)F₄]; a more flexible neutron economy related to the added accelerator-produced neutrons (Table I) and no need to breed ²³³U from ²³²Th; material problems related to operation of a high-power liquid-lead target in a molten-salt environment; impact of target and accelerator on vertical maintenance scheme; *etc.* limit the benefits of directly applying the fruits of the detailed and self-consistent MSBR conceptual engineering design to the preliminary ABC concept. This mapping, however, is guided by the ground rules described in the following Sec. II.D.

D. Design Ground Rules

Ground rules adopted for the ABC Plant Layout Study have been generated to establish more firmly the many options and opportunities available to the molten-salt, fluid-fuel ABC design(s). These ground rules are divided into two broad categories: a) those that set goal plutonium disposition rates and related ABC capacities, irrespective of the characteristics of the ABC primary, secondary, power-conversion, and chemical-plant systems; and b) those ground rules used to establish broad characteristics of the MSBR-derived ABC base case. It cannot be overstressed that this latter base case is defined and generated solely for the attributes of maximal self-consistency and utilization of the MSBR design result, rather than suggesting a design that is optimal from the view point of the ultimate ABC application. In this sense, the ABC base case generated from the ground rules given in Sec. II.D.2. should be considered a "point-of-departure" (POD) reference case.

1. Goal Disposition Capacity

Typically, the plutonium-disposition rate is determined by specifying that M_{Pu} tonnes of plutonium is to be destroyed [$\sim 90\%$ fissioned, with addition of fission boost through highly enhanced uranium (HEU) near end of life (EOL) to achieve $> 95\%$ plutonium burnup] in a chronological time $T_{LIF}(yr)$ by a system that on the average operates at full capacity for a fraction p_f of any given year. Further specification of the number of ABC units, N_{ABC} , each with N_{BLK} target-blanket modules of the kind depicted in Fig. 4, defines the system. The choices of N_{ABC} and N_{BLK} have both developmental, economic, operational, and safety implications. The number of ABC units is dictated largely by the maximum accelerator capacity, $P_B(MW)$, and the maximum amount of electrical power to be delivered to the grid node by that unit, P_E ; typically, power economics suggests $P_E \geq 1,000$ MWe, and (present-day) capacity limits suggest $P_E \leq 1,500$ MWe. For P_E in this range, the number of target-blanket modules, N_{BLK} , is set by target power-density limits, target efficiency, (*e.g.*, neutron coupling, parasitic absorption) in driving a blanket with a given k_{eff} , (passive) safety and local (radioactive) inventory considerations, and cost^{14,15}.

The basis for the choice of target-blanket module size, P_f/N_{BLK} , in past ABC designs¹ was set by limitations imposed by the use of solid targets. These earlier ABC designs for a given value of N_{ABC} suggested ~ 500 -MW modules and a number, N_{BLK} , of such modules. A large number of smaller modules (with the attendant potential for higher cost) sandwiched between large accelerator and balance-of-plant systems economically and

operationally may not be optimal^{14,15}. Furthermore, if nuclear and afterheat safety can be provided by a quick exit of fuel salt to a dump tank (Figs. 3 and 4), the blanket power capacity should not be limited by a desire for passive removal of decay heat from an otherwise unperturbed blanket. In this case, the module size could be set by blanket-criticality, target-power-density, cost, and/or other constraints (*i.e.*, scaling of developmental or prototype power increments). Given that limits imposed by target power density can be pushed upward through the use of flowing, self-cooled, liquid-metal (Pb or the lower-melting Pb-Bi eutectic) target, the thermal power per target-blanket module, P_T/N_{BLK} , can be increased from ~500 MW to values as high as 1,500-2,000 MW⁷.

The magnitude of the module power, at this point in the conceptual development of ABC, is not as important as is the existence of a clear logic for determining it, as long as the module power is not too small. The following “traceable, but not unique” selection process based on the DOE guidance^{4,5} in this area is used:

- The (disposition) technology shall be demonstrated in 20 years.
- A total of $M_{Pu} = 50$ tonnes of weapons plutonium will be disposed in $T_{LIF} = 50$ years; this suggests a burn time of 30 years; a more-aggressive 20 years has been adopted, which portends reduced life-cycle costs¹⁴.
- The life-time average plant availability or capacity factor is $p_f = 0.75$.
- Given that the fissioning of 50 tonnes of plutonium will generate 128 GWyr of thermal energy (assuming complete fissioning), at $\eta_{TH} = 0.40$ thermal-conversion efficiency and a $p_f = 0.75$ plant availability, the electrical-power generation would be $N_{ABC} P_{ET} = 3,413$ MWe. Furthermore, given that this power should be available in $P_E \sim 1$ -GWe chunks, $N_{ABC} \approx 3$ such ABC units are suggested, each generating a total electric power of $P_{ET} = 1,138$ MWe [$P_{TH} = 2,844$ MWt, $P_E = 967$ MWe(net) if the recirculating-power fraction can be held to $\epsilon = 0.15$; $P_E = 1,063$ MWe(net) of the MSBR value of $\eta_{TH} = 0.44$ is used].
- While economic consideration would favor only a few core modules operated at each of the three 967-MWe(net) ABC facilities, presumed limitations on target power density, safety, and/or reliability suggest a greater number of modules. Following the MSBE \rightarrow MSBR scaling philosophy (25%, or one coolant loop)¹⁰ and assuring that the modularization does not become too fine for reasons of lost economies of scale and cost¹⁵, $N_{BLK} = 4$ modules at $2,844/4 = 711$ MWt is adopted by this ABC Plant Layout Study.

It should be emphasized that the basecase ABC plant layout used in this study presumes the complete fissioning at nominally constant beam and fission power (*e.g.*, constant k_{eff} , increasing plutonium blanket inventory) of $M_{Pu} = 50$ tonne of weapons-grade plutonium. Although the process of final “burn down” is not considered by this study, unless highly enriched uranium is introduced near the end of life (EOL) to maintain constant power, only ~90% burnup of the original plutonium inventory is possible (Appendix E), and in fact ~56 tonne of weapons plutonium would be processed.

2. Top-Level ABC Design Options and Basecase Focus.

The main goal of the ABC Plant Layout Study is to translate the systems diagram embodied in Fig. 4 into a “strawman” plant layout using as guidance and as much as is appropriate the subsystem engineering details reported for the MSBR. Nine “top-level” ABC subsystems can be identified from Fig. 2: Accelerator (ACC); Target (TAR, including the Window, WIN); Blanket (BLK); Primary Heat Transport (PHT); Secondary Heat Transport (SHT); Power Conversion or Balance of Plant (BOP); Chemical Plant Equipment (CPE); Operations and Maintenance (O&M); and Safety (SAF). While general, this subdivision is not unique, nor are subsystem boundaries without diffusiveness. For the ABC Plant Layout Study to proceed in the spirit described above (*e.g.*, without a self-consistent and/or optimized preconceptual design), key choices must be made for each of these nine (ten if the window is considered separately) ABC subsystems.

Figure 5 lists for each of these subsystems important “top-level” design choices and the decision path taken to arrive at the base case used to generate the “strawman” plant layout described in Sec. III. The branching options listed on Fig. 5 for each of the main ABC subsystems are not all-inclusive, but many of the design decisions leading to the base case are represented. The reasons and rationale for the choices made, when they can be quantified, are elaborated in each respective subsection in Sec. III. Of equal importance are the “paths not taken” for each subsystem design decisions depicted on Fig. 5; these alternatives will emerge as part of the identification of key issues, the related prioritization of issues, and the identification of alternative design choices that may lead to improved ABC systems, as is addressed in Sec. IV.

III. ABC BASECASE PLANT LAYOUT

A. Overview of Basecase Layout

The design philosophy used to develop the ABC plant layout is based on the use of the Molten Salt Breeder Reactor (MSBR) conceptual design¹⁰ with a minimum of modification. The design changes have been limited to only those necessary to accommodate the accelerator target, to update for inclusion of modern regulatory requirements, and to include minor design improvements. The logic behind this approach is predicated on the exploitation of the careful work of two decades ago that led to the development of the MSBR design. Furthermore, the MSBR concept is the last, and hence latest, molten-salt reactor design available. Because of limited resources available for the ABC Plant Layout Study, a commitment of similar magnitude as given to MSBR was not possible. Although a number of potential improvements (*e.g.*, substitution of an alternative secondary coolant for the sodium fluoroborate) were considered, these options are left as potential design options and not included in the base case.

Table II gives a "top-level" breakdown of key ABC molten-salt (MS) subsystems described in the following subsections. This inventory list, while more extensive than can be resolved by this ABC Plant Layout Study, provides a mechanism for generating an aggregation into key subsystems to be included explicitly in the study. Accordingly, the plant has been categorized into eight major subsystems: Accelerator, Target, Primary System (mainly the PHT subsystems), Balance of Plant, Chemical Processing, Operations and Maintenance, Instrumentation and Controls, and Safety [mainly I&C and Containment Systems (CS)]. As is indicated on Table II, in some cases a clearly defined boundary between these main subsystems does not exist, and, in general, interfacial issues can be important. The following subsections give each design basis and/or rationale based on quantitative scaling information derived largely from earlier accelerator and target/blanket studies and from the MSBR conceptual design. Many of the scaling relationships derived from the MSBR and applied to size ABC components are given in Appendix A; the accelerator scaling, *per se*, is described briefly and heuristically in Appendix B.

B. Main Subsystem Descriptions

A brief description of the main ABC subsystems is given in this section. Key dimensions and capacities, as they relate primarily to the plant layout, are collected in Table III. This table is intended to provide a collection point or parameter "depot" for the ABC Plant Layout Study, and, in terms of completeness and/or self-consistency, should not be considered an ABC design table *per se*.

I. Accelerator (ACC)

a. Overview

The essential elements of the accelerator system needed to provide the design, steady-state current to each of N_{BLK} ABC targets in a spatial distribution that meets both target power density and blanket neutron flux requirements are illustrated in Fig. 6. This figure indicates the technology development required to deliver the linear proton accelerator needed by

ABC from the present or near-future LAMPF device^{16,17}. In addition to being uniquely suited for delivering high proton currents (~ 100 mA) at the requisite energies (≥ 600 MeV), the linear accelerator (Linac) adopted for ABC and embodied in LAMPF has the highest efficiency for converting "wall-plug" AC power, P_{EA} , to beam power, $P_B = I_B E_B$ ($\eta_A = P_B/P_{EA} \sim 0.5$), as well as exhibiting the lowest beam-loss factor [$< 2 \times 10^{-7}/m$ for most coupled-cavity Linacs (CCLs)].

The Injector System (IS, Fig. 6) consists of duoplasmatron, duopigatron, or electron-cyclotron-resonance-heated (ECRH) volumetric ion sources that are capable of steady-state proton currents of >500 mA. The proton beam is extracted from the ion source at ≥ 100 keV for injection into a Radiofrequency Quadrupole (RFQ) accelerator that bunches and accelerates the proton beam to 2.5 MeV. The bunched proton beam emerging from the RFQ is then accelerated to ~ 20 MeV by a Drift-Tube Linac (DTL). The LAMPF uses an older technology based on Cockroft-Walton injectors that feed a 100-MeV DTL. The DTL was invented a half a century ago, and this well-understood and well-developed machine has since been used on all high-current accelerators. After a transition and matching section, or in the case of ABC a FUNneling (FUN) and Bridge-Coupled Drift-Tube Linac (BCDTL), the proton beam emerging from the injector system described above (ion source, RFQ, and DTL) enters a Coupled-Cavity Linac (CCL) developed at Los Alamos in the 1960s for efficient acceleration of protons to energies >100 MeV. More recent consideration has been given to a Coupled-Cavity Drift-Tube Linac (CCDTL) as a replacement for the BCDTL matching section of the CCL Front End (FE) injector. In addition to efficient, higher-energy, and high-current capabilities, the CCL accelerating structure is simple and rugged; Fig. 6 gives the number of RF cavities (cells) and lengths for the CCLs used for LAMPF and anticipated for ABC. Other subsystems that make up the accelerator include the RF power supplies and distribution systems, vacuum systems, cooling, beam diagnostics, control and instrumentation, High-Energy Beam Transport (HEBT) systems for beam delivery to the target, and Beam Expander/Spreader (BES) systems to assure proper beam-on-target distributions for reasons of both assuring target longevity and optimizing blanket neutron flux intensity and distribution.

Figure 6 also indicates both the essential elements of the linear proton accelerator and advances in design and performance required in progressing from LAMPF¹⁶⁻¹⁸ and the ATW/ABC^{1-3,14,19,20}. These accelerators do not provide a continuous current of protons to the spallation target, but instead deposit a sequence of proton "bunches", each contained in the bottom of an RF electromagnetic potential well. In addition to the degree to which each RF wave is filled, the time-averaged intensity of protons delivered to the target is determined by the fraction of the time that the RF wave-train is on (*i.e.*, duty cycle) and the spacing within a given RF wave train between RF waves that actually contain protons and those that are empty. Hence, the increased current required of the ABC facility can be achieved by increases in: a) the degree to which each RF wave is filled with protons (LAMPF presently is $\sim 25\%$ "filled" in this regard); b) the fraction of the time when a packet of RF-waves will be found (LAMPF presently has a duty factor of $\sim 6\%$, not to be confused with availability, which for LAMPF is $\sim 85\%$); and c) the fraction of RF-waves within a given packet that actually carry or "push along" a proton bunch (for LAMPF 25% of the RF cycles actually contain proton bunches). By filling each RF electromagnetic well to the "brim", by filling all of time with a continuous train of RF waves, and by using each of these continuous RF waves with beam bunches of $\sim 2 \times 10^9$ protons/bunch (ppb), the

the accelerator current can be enhanced by a factor of ~250 over the $E_B = 800$ -MeV LAMPF^{16,17}, as is indicated on Fig. 6. The means by which the LAMPF current can be increased by the requisite factor to meet ABC needs remains primarily an issue of cost, schedule, and the accommodation of the range of uses projected for a higher-power LAMPF²⁰, rather than the longer-term technology developments required to achieve full ATW conditions. The key technical issues of a high-power ATW proton linear accelerator¹⁸⁻²⁰ adopted for the ABC Plant Layout Study include:

- funneling of two single beams into the last accelerating stages.
- beam loss along the acceleration chain leading to unacceptable heat loads on and activation of accelerator structures.
- efficiency and reliability of high-power RF power supplies.
- RF operational control at high beam loadings.
- (beam) fault recovery and other off-normal conditions (*e.g.*, RF-power and AC-grid surges; CCL module failure; beam failure; events driven by HEBT, BES, or window/target/blanket malfunctions, *etc.*)
- component reliability and accelerator maintainability.

Issues of lesser importance and concern for the ABC accelerator include: RMS beam physics, peak current levels, beam brightness, beam stability, accelerating gradients, thermal loads, and RF power sources. Table III lists key accelerator parameters anticipated for the ABC, and when possible value ranges are given; a main goal of any subsequent conceptual design is to complete Table III on the basis of optimized cost, schedule, and risk. An approximate accelerator scaling relationship is developed in Appendix B to give an example of the kinds of tradeoffs needed to complete an ABC accelerator "strawman"-design table for use in subsequent conceptual design studies.

b. Target Interface

The proton beam, upon achieving full energy and undergoing splitting into beamlets for use in each 711-MWt Target/Blanket module, is carried to the secondary containment building by the High-Energy Beam Transport (HEBT) system. After passage horizontally through a Main-Beam Isolation Valve (MBIV, Fig. 2), the ~ 800-1,000 MeV, $I_B/N_{BLK} \approx 20$ -mA beamlet must be bent downward 90° and decreased in current density by means of a drift-tube beam expander/spreader (BES). Bending would occur by passage through a horizontal magnetic field. The optimization described in Appendix F suggests a bending radius of 2.8 m and a magnetic field intensity of 1.6 T. The vertically directed beam would be transported through a field-free region of length $L_{EXP} = 10$ m, where the beam space charge is expected^{21,22} to enlarge the beam to an acceptable footprint ($?? \times ??$ m, $???$ A/m²) at the Window/Target. While the economics of the beam bending and expansion *per se* (Appendix F) does not appear to be an important driver, the impact on the size and cost of the secondary containment building, as well as the impact on the Target/Blanket (vertical) maintenance scheme, can be significant.

2. Target (TAR)

a. Overview

Figure 7 is a schematic of the required target function. The target converts the high-energy ($E_B \geq 500$ MeV) protons generated by the accelerator to lower-energy (< 20 MeV) neutrons and transports these primary neutrons to the blanket. In performing this function, the target must be cooled sufficiently for steady-state operation and must be designed to reduce risk related to radiological release or other detrimental consequences resulting from off-normal operating conditions (*e.g.*, loss of target coolant, maladjusted beam distribution, *etc.*).

As elaborated in Appendix C, the conversion of high-energy protons to neutrons relies on intranuclear reactions between the incident protons and the nucleons in the target material. Consequently, to maximize neutron production, the target material should have a large number of nucleons per individual nucleus; a high-Z material is preferred. While the protons can interact directly with bound neutrons followed by ejection from the nucleus, the emitted neutrons tend to be peaked forward and to have very high energies (*e.g.*, in the range from 20 MeV to E_B); these neutrons are poorly used in the blanket, since the slowing-down length is large, even for efficient neutron-moderating materials, and heavy shielding behind the target is required (Fig. 7). Neutrons of more utility to a moderating, thermal-neutron blanket are created through the interaction of a proton with the nucleons in a nucleus in general, thereby leaving the nucleus in an excited state after interacting with the proton. Release of excess energy in the excited nucleus occurs by nucleon evaporation; a substantial portion of these evaporated nucleons are neutrons. These evaporation neutrons are emitted isotropically with an average energy in the range 1-2 MeV. The number of neutrons generated by a given proton energy depends on the target material.

While maximizing the generation of low-energy neutrons is important to the overall efficiency of ABC, the ultimate target performance depends on an ability to transfer usefully and efficiently these neutrons to the blanket. This efficiency depends on the neutron absorption characteristics of the target material(s) and the volumetric distribution over which the neutrons are generated (*i.e.*, whether the target produces a highly-peaked, intense neutron distribution, or whether the distribution is more evenly distributed; the volume required to achieve maximum neutron production for a given neutron-source distribution is also important).

The target absorption characteristics depend not only on intrinsic nuclear parameters, but also on the amount of thermalization that occurs in the target. The degree of thermalization in turn is strongly dependent on the type and quantity of coolant used, as well as the target geometry and configuration. Similarly, the neutron-source distribution also depends on the target material (density), coolant fraction (*i.e.*, the "effective" target density), and geometry. The ABC target design, with an overall goal of achieving high thermal neutron fluxes in an acceptable blanket volume V_{BLK} with a minimum accelerator capacity P_B , therefore, will have to optimize neutron production to minimize neutron absorption in the target; to maximize neutron leakage to a blanket of a size that is acceptable for engineering purposes; and to distribute the source as evenly as is possible over the volume of interest. Achievement of the first three goals also leads to a need to minimize the coolant fraction.

The ability of the ABC target to achieve the functional goals described above depends on three specifications: a) target material, b) target geometry, and c) target heat-removal system. All three specifications are interdependent, however, and this interrelationship must be fully understood before an effective and optimal ABC target design can be realized. Each target technical issue is discussed in Appendix C, which gives a broad technical perspective of the ABC target requirements and options.

b. Target Components

Window: The accelerator window is a crucial component in the ABC system. In the current ABC design, the window is an integral part of the target structure and is cooled by the flowing liquid-lead target material. A window failure, therefore, would cause significant downtime for cleanup of the accelerator vacuum system that would be contaminated by the lead. Because the window is cooled solely by the lead, which operates at high temperature, it must maintain strength at high (~1,000°C) temperatures. This requirement, coupled with the need to endure a large proton and neutron fluence without serious degradation to mechanical properties, makes the material choice problematic and difficult without extensive experimental investigation. Alternate proposals exist for possible window configurations that attempt to remediate the high-temperature requirement by providing the window with a separate coolant other than the lead. This possibility and associated benefits and disadvantages is discussed in Appendix D.

Lead Cooling System: The flowing lead can easily remove the heat deposited by protons, neutrons, and gamma rays, but removal of the heat deposited in the target structure is more complicated. Generally, recovery of this power at temperatures where efficient conversion to electrical power is possible is not being considered; the beam power will be rejected to the atmosphere as low-grade heat. Lead, like other heavy metals (*e.g.*, mercury and bismuth) does not wet containment materials well. The inability to wet container surfaces causes a significant decrease in the obtainable heat-transfer coefficients, as well as causing difficulty in predicting the lead flow distributions near structural surfaces. This uncertainty generates a requirement for a large degree of experimental validation for any flowing heavy-metal target designed for the target heat fluxes and target heat fluxes and power densities (???)MW/m², ???MW/m³) envisaged for ABC. Another important issue with regard to the lead cooling system is the choice of secondary coolant and the associated heat-exchanger design. The secondary (target) coolant presently being considered is NaK, although some industrial cooling salts (*e.g.*, HiTech) are also under investigation. The main requirements for the secondary coolant is compatibility with the lead, in the event of a heat-exchanger leak, and operation at a low pressure while maintaining compactness in the heat-exchanger design. The poor wetting characteristics of liquid lead make the heat-exchanger design another prime candidate for experimental validation.

Lead Freeze/Thaw System: The use of a liquid metal for the neutron-producing (neutron-spallation/evaporation) target generates the requirement for an additional system for melting and freezing the lead material. As with most materials, lead expands upon melting and contracts while freezing. If the phase change is allowed to occur within the target system, damage would likely occur to the structural containers (especially in the thin-walled heat exchanger tubes) because of the additional stress that accompany the phase change, which cannot be accurately controlled. A lead storage container or reservoir, therefore, is provided to accommodate phase changes. A free surface is maintained in the reservoir, and spatially dependent heaters would be used to control the melting process.

The use of this reservoir, however, means that the lead must be maintained as a liquid while residing within the main target system, even if the accelerator beam is off. Heaters, therefore, are required to be applied on the target structure are required. The use and survivability of these heaters in the high radiation environment of the target may present a key design issue. Also, an injection/drainage system must be used to transfer the lead to and from the reservoir. The transfer medium is envisioned to be an inert gas (*i.e.*, argon) pressurization system, like those used in liquid-metal fission reactors²³.

Lead Cleanup System: Generally, lead is highly corrosive to most materials, especially in a flowing environment. The slow addition of a large number of additional chemical species that are generated through the nuclear spallation/evaporation process, adds uncertainty to the expected rates of corrosion and, therefore, uncertainty to the target structural lifetime; once again, this issue raises a need for experimental efforts to resolve the uncertainties. At some point during the ABC operation, the lead may become unusable because of extensive contamination from nuclear spallation/evaporation products, which could affect fundamental thermodynamic properties the neutron-producing ability. For the conditions envisaged for the ABC target (800 MeV, 20 mA/target), the rate of lead destruction and "impurity" injection amounts to ~ ??? kg/yr, or ~??? %/yr of the active lead inventory. If this level of contamination proves unacceptable, the lead will either have to be replaced and, therefore, contributes to a (mixed) waste stream, or the lead would have to be cleaned and recycled. No processes have been identified to clean up the lead, and if needed, will require a design and development effort.

3. Primary System

As indicated on Table II, the primary system consists of all components located inside the primary vessel (core), the intermediate heat exchangers (IHXs), the fuel salt pumps, and all the primary system piping that interconnect these components. In the parlance of the EEDB Program of Cost Accounts,^{12,13} the Primary System is essentially the Reactor Plant Equipment. For the purposes of the ABC Plant Layout Study, this system is approximately defined by those components that contain an appreciable quantity of fuel salt, with the exception of the drain tank and the chemical-processing equipment. Modified Hastelloy-N is used for the entire primary system because of its compatibility with the fuel salt. This fuel-salt boundary is comparable to the fuel cladding in a conventional fission reactor, and is identified as the primary containment boundary (Fig. 4). The compatibility issue was developed on the basis of the MSBR design experience (UF_4 , heavy ^{233}Th loadings); the plutonium-based salt is expected to be substantially different for ABC, especially with regard to REDOX potential. Each of the major Primary System components is described in detail below, and is shown in Fig. 8 as: Core; Fuel-Salt Pump; Intermediate Heat Exchanger; and the Reactor-Cell Vessel and all associated piping.

a. Core

The ABC core corresponds to the MSBR core in size and composition, aside from the central spallation target. As indicated on Table II, the Core consists of Target/Blanket decoupler, blanket coolant (*i.e.*, the fuel salt), the Moderator, the Reflector, the Reactor Vessel, and all control/shutdown rods. For the purposes of the ABC Plant Layout Study, the Core has been designed with an overall power density of $P_F/V_{COR} = 22.2 \text{ MW/m}^3$, which is equal to that of the MSBR. The overall size of the core shown in Fig. 8 was determined from this power density and the basecase overall thermal power per

Target/Blanket module of $P_F = 711$ MW. For a square cylinder core shape, the core diameter and height are 3.5 m. These dimensions compare to the MSBR core diameter and height of 5.2 m and 4.0 m, respectively.

The Core internal structure is similar to that of the MSBR. Graphite blocks or stringers are used to moderate the neutron flux and to form flow channels for the fuel salt. Each stringer is 0.10 m on a side and has a 0.034 m hole drilled through its center. Fuel salt flows both inside and between adjacent stringers. A total of 962 such graphite stringers will be required for each ABC Target/Blanket assembly. Although incomplete, parametric neutronics studies of other graphite/fuel-salt configurations indicate an important trade off between material lifetime, quantity of nuclear waste, and operational complexity as the fuel-salt/moderator ratio is varies; this material is summarized in Appendix E, which also lists the damage rates in the graphite for a number of moderator/fuel-salt ratios.

Of the 962 graphite stringers, six are non-standard: three are designed to accommodate graphite control rods and three are fitted for boron carbide shutdown rods. The principle of the control-rod action is based on the displacement of fuel salt to adjust reactivity. These control rods are inserted to start up each driven target-blanket assembly, since the surrounding regions are undermoderated; by displacing fuel salt and introducing additional moderator, reactivity is introduced. These control rods must be removed to reduce the reactivity. Although this introduces a potential failure mechanism, because of density differences the graphite tends to float in the fuel salt unless constrained. Electromagnetic control-rod drives may be used so that in the event of an electrical failure the control rods float out of the core and reduce the reactivity. In addition to the control rods, three shutdown rods are included. These rods are composed of Hastelloy-N-clad boron carbide and are inserted to reduce the reactivity. By including these shutdown rods, the effects of an inadvertent accelerator start-up are mitigated. The shutdown rods would normally be fully withdrawn during operation.

The active core region is surrounded by a 0.75-m-thick graphite reflector. This thickness was used in the MSBR conceptual design. Although the ABC core is smaller, a similar reflector thickness was chosen. The blanket-vessel inner diameter, therefore, is 5.0 m.

b. Fuel-Salt Pump

The fuel salt moves upward through the core at a nominal velocity or $v_{FS} = 0.88$ m/s ($\Delta T = 139$ K, $\dot{M}_{FS} = 2,150$ kg/s, fuel-salt volume fraction $f_{FS} = 0.13$) and enters an upper plenum located between the core and the reflector. The flow is divided at this point and is passed through the radial reflector by two flow channels machined in the graphite. Two identical loops primary are used to transfer the fission heat in the fuel salt to the secondary coolant. Each loop consists of a fuel-salt pump, an IHX, and the associated piping. The fuel-salt pump design was adopted from the MSBR fuel-salt pump design¹⁰ without change. Although the pumping requirements of the two systems differ (1.0 m³/s for the MSBR versus 0.55 m³/s for the ABC), the pump size has been taken to be the same as that of the MSBR. Guidance on scaling the pump size was not found, nor could it generated within the scope of the ABC Plant Layout Study; the direct adaptation of the MSBR pump design results in a conservative size allowance in the layout.

The fuel-salt pump is of the centrifugal sump-pump design and is illustrated in Fig. 9. The pump bowl is 2.0-m in diameter and is 1.5-m high. A free surface is maintained in the

pump bowl because the pump bowl serves as a surge volume for the entire Primary System. Because a free surface is maintained in the pump bowl, the pump must be placed in elevation above all the Primary System components. Graphite blocks may be positioned around the pump impeller to limit the fuel salt volume held up exterior to the blanket. The fuel-salt volume in each pump has been estimated to be 1.0 m³ or 8% of the total fuel-salt volume.

The pump motor is located on the maintenance floor several meters above the impeller. This provides ample room for shielding the motor from the intense radiation field at the level of the pump bowl. Pumps of this kind were operated for many thousands of hours as part of the MSBR project. Molten-salt pumps of this large capacity, however, have never been built. It was the consensus of the MSBR project that scale up of the pump design would not be difficult.

c. Intermediate Heat Exchanger

Fuel salt flows directly from each fuel salt pump into the associated IHX, as is shown in Fig 8. The IHX design is adopted from the MSBR design. The IHX is a shell-and-tube heat exchanger with a somewhat unconventional internal arrangement to accommodate remote maintenance and to limit the exo-blanket fuel-salt inventory. As is shown in Fig. 10, the IHX dimensions are nearly identical, with the exception of the height. Modifications to this design were limited to the following items: a) shortening the tubesheet-to-tubesheet distance from 7.07 m to 5.25 meters; and b) converting the concentric secondary-salt outlet pipe into a more-conventional side outlet. The size, number, and spacing of tubes remains unchanged. The fuel salt enters through a vertical tubesheet. After traveling through the tubes, each of which assumes the shape of an inverted "L," the fuel salt flows down to the lower horizontal tube sheet. The secondary coolant salt side of the IHX was subjected to design modifications, but these modifications are described more fully in the Balance of Plant description (Sec. III.B.4.).

As is shown in Fig. 10, the IHX has an overall height of 6.55 m and a shell diameter of 1.75 m. The shell contains a central downcomer with a 0.51-m diameter. Surrounding this downcomer are 5,803 tubes arranged on a 19.1-mm pitch. Each tube has an outer diameter of 9.5-mm. The tubes are bent into a sinusoidal configuration in the upper portion of the IHX to accommodate thermal expansion. Over the remainder of their length, the tubes are knurled in a spiral pattern to enhance the overall heat-transfer coefficient.

d. Reactor Vessel and Primary System Piping

The reactor vessel is fabricated from modified Hastelloy-N alloy. The inner diameter is 5.0 m and a wall thickness is 50.8 mm. The vessel has a maximum height of 5.0 m at the center. Both the top and bottom heads are spherical, with a 16-m radius of curvature. The upper head is removable to allow replacement of the graphite stringers and inspection of the reactor internal components. The upper-head design is complicated by the need to accommodate the (removable) the target thimble. The reactor vessel is similar in design and shape to that of the MSBR. The ABC vessel is not as high and has a smaller diameter. A remote flange was used in the MSBR top-access design to lower the temperature and neutron flux on the upper head connections. A similar arrangement is expected for the ABC, although this detail is not shown in Fig. 8.

All of the primary system piping is made of modified Hastelloy-N. The piping used is 0.40 m in diameter with a 12.7-mm wall thickness. For a mass flow rate of 1,073 kg/s, the flow velocity in the primary system piping is 4.9 m/s, which is the maximum flow velocity in the primary system. The other flow velocities in the primary system are 0.88 m/s in the core, and 2.0 m/s inside the (5,803) IHX tubes.

Hastelloy-N alloy was chosen for all Primary System components because of the experience with molten-salt compatibility. This adequate compatibility, however, was developed on the basis of the MSBR design experience (UF_4 , heavy ^{232}Th loadings); the plutonium-based ABC fuel salt is expected to be substantially different, particularly with respect to the REDOX potential. None of the other potential materials has undergone as extensive testing with fluoride salts. One possible exception to the use of Hastelloy-N is in the reactor vessel portion of the target thimble, however. The thimble will be exposed to a large neutron flux ($\text{???} / \text{m}^2/\text{s}$), and is expected to have short lifetime (??? months). If the radiation resistance of Hastelloy-N is insufficient to provide at least a one-year operational lifetime, an alternate material may have to be used. Modified 9Cr-1Mo ferritic alloy has been considered for this application because of a superior irradiation performance. The molten-salt compatibility of this alloy, however, is not as good as that of Hastelloy-N, but its corrosion lifetime in molten-salt may prove to be greater than the Hastelloy irradiation lifetime in the high-flux region of the target thimble.

4. Heat-Removal Systems

The Heat-Removal systems (Table II) include the secondary coolant system and its associated equipment, the steam generator, the steam reheater, and the supercritical-steam (SCS) power-conversion system. All of these systems may be considered to comprise the BOP and corresponds in large part to the designation often attributed to the non-nuclear portion of nuclear power plants. The intermediate coolant loop is not found on current generation light-water fission reactors (LWRs) and is, therefore, somewhat difficult to characterize, although detailed designs for the Liquid-Metal Breeder reactor²³ (LMBR) are applicable here. While the secondary coolant will contain appreciable radioactivity as a result of activation of the coolant in the IHXs, it should contain neither fuel nor fission products unless leaks occur in the IHX tubes. The secondary salt loop is included in the ABC design for the same reason it was incorporated into the MSBR design: primarily to increase the overall system safety margin.

a. Secondary-Coolant System

A secondary coolant system is incorporated into the ABC design because, first, the secondary salt loop helps meet the three-barrier requirement for containment of fuel salt. Secondly, this loop reduces the probability of transporting fuel or fission products into the turbine and related equipment in which radioactive material containment cannot be accommodated. Lastly, the secondary loop reduces the chance of fissile material precipitation by reducing the probability of steam ingress into the primary system. For all the potential benefits, however, the secondary system is not without drawbacks related primarily to added system complexity, reduced overall conversion efficiency, and added cost.

The secondary salt chosen for the ABC is taken from the MSBR design and is a sodium fluoride, sodium-fluoroborate eutectic mixture. This coolant is commonly referred to as

sodium fluoroborate, with the assumption of an eight percent sodium fluoride addition. Extensive testing was performed on this salt as part of the MSBR project. Sodium fluoroborate combines good heat-transport and fluid-flow properties with low cost, acceptable chemical and radiation stability, and compatibility with Hastelloy-N. This material is not an ideal choice for a secondary coolant, however, but its combination of advantages was determined to outweigh its disadvantages.

Most of the drawbacks to use of sodium fluoroborate are well known and were studied extensively as part of the MSBR program. One of the concerns is the requirement for a cover gas. Sodium fluoroborate undergoes a thermal decomposition that evolves BF_3 . This gas must be reintroduced, along with an inert cover gas, to prevent changes in the NaF- NaBF_4 ratio. The mole fraction of NaF must be controlled to prevent gross changes in the fluid properties of the eutectic mixture. The BF_3 evolved is a chemical hazard, but compared to the other chemical and radiological hazards associated with a molten-salt system, this concern is minor. The off-gas system for the secondary salt loop will be more complex than it would be if an alternative salt were chosen, but this complication is not sufficient justification for use of a less characterized salt.

Another potential problem associated with the use of sodium fluoroborate is its corrosiveness when contaminated with water; minor steam leaks into the secondary loop may not be tolerable. In the absence of water, the corrosion rate of Hastelloy-N in sodium fluoroborate has been shown^{10,11} to be approximately $5.0 \mu\text{m}/\text{yr}$. This rate increases dramatically to over $500 \mu\text{m}/\text{yr}$ in the presence of water. It may prove impractical to prevent water ingress into the fluoroborate by way of the steam-generator and steam-reheater tubes (Fig. 3), and the moisture removal capability of the off-gas system is limited. The present design does not use duplex tubing in either component, so in-leakages are expected to occur over the lifetime of the plant. Large leaks would require shutdown and salt cleanup. Pinhole leaks, however, may be sufficient to accelerate corrosion and can reduce the secondary-loop component lifetimes. This issue must be accommodated in the detailed design either through the use of duplex tubing, more aggressive moisture removal equipment, or conservative design choices with regard to equipment wall thicknesses.

The feedwater temperature requirement is 56 K lower than the alternative secondary coolant salt, LiF- BeF_2 . The liquidus temperature of the sodium fluoroborate is 658 K, compared to 732 K for the LiF- BeF_2 . The feedwater requirements of the reference steam system are already sufficiently high to require a complex feedwater design¹⁰. Additional increases in the minimum feedwater temperature are not justified by the reduced complexity of the secondary-salt system if LiF- BeF_2 were to be used.

Sodium fluoroborate traps tritium gas leaking or diffusing into the secondary loop from the primary loop. Limited testing [Ref. 24, p. 57] has shown that a large fraction of the tritium that reaches the fluoroborate can be trapped and removed before diffusing into the steam system by way of the steam generator and steam reheater. The tritium is converted into a chemically combined and water-soluble form (????), and then removed by the off-gas system. Greater than 90% of the tritium added under steady state conditions was trapped in the limited tests that were performed. The actual mechanisms responsible for this trapping, however, are not understood.

The secondary-coolant-salt system consists of the shell side of the IHX (Fig. 10), the shell side of the steam generator, the shell side of the steam reheater, two coolant salt pumps, and the associated piping. Figure 11 shows two views of the steam generator, Fig. 12 depicts the steam reheater, and the secondary-coolant-salt pump is similar to that illustrated in Fig. 9 for the fuel salt. The coolant salt enters the IHX through a central inlet located at the top of the IHX. The salt then flows down through a central 0.51-m-(outside)diameter downcomer and into the lower tubesheet. The flow is directed outward and flows upward and past the tubes. A number of disk- and donut-shaped baffles are included in the shell to increase the overall heat transfer coefficient. The primary modification to the MSBR IHX design to accommodate the ABC application occurs in the top of the shell, where the concentric coolant salt outlet connection has been replaced by a more-conventional plenum and outlet through the side of the shell. The IHX shell measures 1.71 m in diameter, with a thickness of 12.7 mm. The IHX is 6.55-m high, which is slightly shorter than the 7.32-m height of the MSBR design.

The heated secondary coolant salt flows from the two IHXs and is combined into a single pipe for passage through the vessel that forms the reactor cell. This pipe leads directly to the steam-generator cell. The coolant-salt flow splits before satisfying the steam-generator and steam-reheater loads. The steam generators (Fig. 11) and the steam reheaters (Fig. 12) are similar, with only the design pressures, sizes, and thermal capacities changing. In both heat exchangers, the coolant salt enters at 894 K and exits at 728 K.

In systems using more conventional coolants, division of the secondary-coolant flow between the two unequal loads would be accomplished by the use of flow control valves. The required valves, however, have not been developed for use in high-temperature salt. In lieu of the need to develop these valves, flow control in the ABC design, would be accomplished through speed control of the two coolant-salt pumps. In each of the coolant-salt loops, a pump is located directly downstream of the respective heat exchanger (*e.g.*, the steam generator or the steam reheater). Feedback from temperature detectors on both the coolant salt and steam sides should allow adequate flow control. The pumps designed for use in the MSBR utilized variable speed motors, and should be capable of the fine adjustment necessary for flow control.

The coolant-salt piping is constructed entirely of Hastelloy-N. Two sizes of pipe are used. Pipe of 0.51-m diameter is used for all the connections within the individual cells (reactor vessel and steam generator). The two flows join before passing between the two (secondary-coolant-salt and the steam-generator) cells to minimize the number of cell penetrations. This larger piping uses a 0.61-m-diameter pipe. The flow velocities in the small-bore pipes range from 1.2 m/s in the steam reheater piping to 7.8 m/s in the steam-generator piping. The velocity in the large-bore piping is 6.0 m/s. The coolant-salt piping sizes can be increased with little additional penalty if it is determined that these velocities are too high. The coolant-salt volume does not represent a critical issue, since the sodium-fluoroborate secondary salt is relatively inexpensive and the radioactive inventories are low.

b. Steam Generator

The steam-generator design illustrated in Fig. 11 is taken from the MSBR design; a few minor modifications were made primarily to optimize the layout for the ABC design. For the ABC layout, the inlet and outlet plena were changed, as were the overall physical dimensions. The overall principle of the design remains unchanged, however, as is also

shown in Fig. 11. The MSBR design philosophy led to the use of many smaller steam generators and steam reheaters to minimize the required wall thicknesses for this (high-pressure) SCS system. The steam generator was sized for 121 MW, and the reheater was sized for 36.6 MW. Sixteen steam generators and eight reheaters were used for the 2,250-MW MSBR power plant. Each ABC core develops a much lower thermal power ($P_{TH}/N_{BLK} = 711 \text{ MW}$), and it was determined that a single larger steam generator and reheater were preferable to multiple smaller units. A single steam generator was, therefore, designed to accept the entire power load of approximately 617(???) MW.

The MSBR steam generator used a U-shell, U-tube design to minimize the diameters of the inlet and outlet plena and their associated tubesheets. This configuration has been adopted for the ABC. The results of sizing calculations are a total length, including the inlet and outlet plena, of 7.3 m, a total height of 6.0 m, and a shell diameter of 1.5 m. Because of the high pressures in the steam side of the steam generator (up to 29 MPa), thick walls are required for the inlet and outlet plena, and for the tubesheets. The inlet and outlet plena are 0.25-m in thickness, and the tubesheets are 0.5-m thick. It may be possible to reduce the tubesheet thicknesses as part of the detailed design, because conservative stress calculations were used to determine these thicknesses.

One of the major changes to the steam-generator design was the relocation of the inlet and outlet plena. This change reduces the number of curves in the steam-generator shell and simplifies the piping layout. The U-shell steam generator is oriented on the side, as is shown in Fig. 11. Hot coolant salt enters the upper leg through the side of the shell. This salt passes along the tube bundle down to the lower leg, at which point it exits through the side of the shell. The feedwater enters the lower leg through the end of the shell. The inlet plenum is hemispherical, with the tube sheet forming the flat surface. The feedwater passes through the tubesheet into the 4,115 tubes. The resulting superheated steam exits through an outlet plenum that is identical to the inlet plenum.

The steam generator has not undergone detailed design, but significant difficulties are not expected. The use of a U-shell minimizes the shell diameter and allows the use of a single steam generator for the entire plant load. Testing of this design will be required prior to construction of the full scale version.

c. Steam Reheater

Steam reheat is standard practice in supercritical-steam systems to extract the maximum work from the high-pressure fluid. The MSBR steam-system design used full-flow reheat, and this approach has also been adopted for the ABC. The MSBR reheater design (Fig. 12) is based on a conventional shell-and-tube design that uses a cylindrical shell. Eight smaller reheaters were used, and each were sized to transfer 36.6 MW. As discussed in Sec. III.B.4.b., it was determined for the ABC application that a single large component was preferable to multiple smaller units. A single reheater, therefore, is used and sized to transmit 93.6 MW. The actual reheater design is a replica of the steam generator, as is shown in Fig. 12. This choice was made primarily to simplify the BOP layout. Use of a U-shell/U-tube design is expected to increase the cost of the reheater, however, but this penalty is outweighed by the simplification in layout that results from the mirroring of flow paths to and from the steam generator and reheater.

The reheater has a shell diameter of 0.8 m, a total height of 3.0 m, and a total length (including the inlet/outlet plena) of 6.0 m. The operating pressure in the reheater is much lower than in the steam generator (4.0 MPa *versus* 25.5 MPa), so the required wall thicknesses are much reduced. The inlet and outlet plena are 0.05-m thick, and the tubesheet is 0.2-m thick. As with the steam generator, these thicknesses are likely to be reduced during the detailed design process. The calculations used to generate these parameters are intended only to provide an upper bound for use in this design.

The uncertainties in this design are few and are primarily those noted for the steam generator. Testing performed for the steam generator will for the most part be applicable to the reheater. The only difference in the two designs, other than physical size, is the steam condition. The inlet reheat steam is to be preheated to 617 K, which is actually below the freezing point of the sodium-fluoroborate coolant. Additional testing beyond that required for the steam generator will be required to show that partial freezing of the secondary coolant salt either does not occur or does not cause difficulties if it does solidify.

d. Supercritical Steam System

The steam system chosen for the ABC was taken directly from the MSBR conceptual design. The MSBR steam system depicted in Fig. 13 was adapted from the Bull Run Steam Plant design²⁵. The Bull Run unit is a high-efficiency, coal-fired steam plant that utilizes supercritical steam. The steam enters the high-pressure turbine at 811 K and 24.5 MPa. These conditions are adopted for the ABC.

Supercritical feedwater enters the steam generator at 25.9 MPa and 644 K. The feedwater is heated by the sodium fluoroborate coolant salt to 811 K. The steam passes through the high-pressure turbine and exits at 4.1 MPa and 561 K. The steam then passes into a reheat steam preheater that uses first quality supercritical steam to heat the reheat steam to avoid the salt freezing in the reheater. Steam leaves the preheater at 3.8 MPa and 617 K. The reheater brings the steam back to 811 K, the temperature at which it enters the intermediate pressure turbine. The steam passes through the intermediate-pressure turbine, through the low-pressure turbine, and into the condenser. A full-flow demineralizer is used to prevent fouling of the once-through steam generator and reheater. After passing through the demineralizer, the condensate enters the feedwater heater/booster equipment. A complex system of feedwater preparation is needed because of the high feedwater temperatures required to prevent freezing in the steam generator. The majority of the pressure increase is provided by steam-turbine-driven booster pumps. The final feedwater heating occurs in feedwater mixers that blend the high-pressure steam (23.8 MPa) from the reheat steam preheater with the feedwater. Electric feedwater booster pumps are then used to increase the feedwater pressure to 25.8 MPa prior to its introduction into the steam generator.

The supercritical-steam cycle described above is complex and costly. The choice of this cycle was driven by two factors: a) the high feedwater temperature required to prevent freezing of the secondary coolant salt in the steam generator; and b) the efficiency gained by going to a supercritical-steam cycle. It was determined in the MSBR design that the high feedwater-temperature requirement was best met by blending first quality steam out of the steam generator with feedwater prior to obtaining any mechanical work. Direct mixing of condensate with steam produces violent reactions from bubble collapse. This condition is averted in the supercritical-steam cycle because the two phases are indistinguishable. A simple spherical chamber is used for mixing. The second factor in

choosing the supercritical-steam cycle is gain in thermal efficiency. The best subcritical-steam cycle devised was a modified Loeffler cycle, which yielded a net plant thermal efficiency lower than the reference supercritical cycle (41.1% versus 44.5%). The combination of simplified feedwater mixing and higher thermal efficiency outweighs the added equipment and design complexity of the supercritical-steam cycle.

5. Chemical Processing

Like the MSBR, the chemical processing equipment is an integral part of the ABC design. The MSBR has been described as a "chemist's reactor,"^{10,11} because of the importance of chemical control and separations to the design and operation. The ABC may be constrained less by chemistry limitations, because breeding is not envisioned for the system and the neutron balance is considerably relaxed in a driven (subcritical) reactor (Table I). The primary mission of the MSBR was breeding of ^{233}U from ^{232}Th for an economically attractive doubling time. The ^{233}Pa produced as an intermediate step must be removed from the fuel salt before absorbing a neutron and being lost from the fuel cycle. Furthermore and of great importance to the somewhat tenuous MSBR neutron balance, parasitic absorptions must be minimized to maintain an acceptable breeding ratio and doubling time. The removal times for ^{233}Pa and certain parasitic fission products were short, and this imposed severe restrictions on the chemical processing equipment for MSBR.

While not as serious, chemical processing, nevertheless, remains important to the ABC design. Chemical processing is needed in ABC to prevent undesirable changes in the fuel solubility (because of buildup of certain fission products), to reduce material interactions (*e.g.*, the tellurium embrittlement of Hastelloy-N), to maintain fuel concentration within the desired narrow range, and to prepare the fission products for disposal. Additionally, the cost-driven necessity to use efficiently the accelerator-produced neutrons, the desire to limit actively circulating inventories, and waste minimization are important drivers of the chemical plant equipment design. While the chemical processing equipment is expected to be neither as numerous nor as large as was required for the MSBR, it is expected to occupy a large portion of the containment. All of the chemical processing equipment is described in the following sections.

a. Fuel Processing

Fuel processing for the ABC system can be divided into two parts: a) preparation of the initial 67 mol% ^7LiF – 33 mol% BeF_2 fuel salt; and b) preparation of the plutonium-containing feed material. The preparation of the 67 mol% ^7LiF – 33 mol% BeF_2 fuel salt has been described for the MSRE and MSBR, and the same kind of system is required for the ABC system. The details of the system have been described elsewhere^{10,11}. The preparation of the plutonium-containing feed material and method by which the fissile material is to be introduced into the reactor, however, are described.

The plutonium feed for the ABC fuel salt be a ^7LiF – PuF_3 eutectic mixture. The process for preparing such a mixture follows. The excess weapons plutonium, which would require no preprocessing, would be converted to the trifluoride by hydrofluorination in the presence of a small amount of hydrogen (*i.e.*, probably <2% H_2) in the temperature range 500 - 600°C. The hydrogen prevents the formation of the tetrafluoride and the volatile hexafluoride. The PuF_3 would be mixed with ^7LiF in the ratio 19.5 mol% PuF_3 – 80.5

mol% ^7LiF and heated above the eutectic temperature of 743°C . The mixture could be cooled and stored for later use or injected in the fuel salt. If the mixture is cooled and stored for later use, several schemes exist for introduction into the reactor. The mixture could be preheated to 750°C and the liquid blended with the fuel salt in the pump bowl, or small pellets of the eutectic mixture could be added to the pump bowl where it would dissolve in the fuel salt. Fail-safe procedures would be implemented to guard against the introduction of excess reactivity at this point in the process.

In general, the processing equipment that is required for the plutonium feed material preparation consists of a two gloveboxes, each of which being fitted with two or three furnace systems and nickel reaction chambers that is fitted with gas handling capabilities. Details relating to the size and location of the gloveboxes, the furnace systems, and the reaction chambers have not been defined. Criticality safety issues would be important during all stages of the design.

b. Drain Tank

The drain tank is located below the reactor vessel in an isolated vault. This tank is sized to accept all the fuel salt, along with a fraction of the secondary coolant salt that might enter the primary system during an IHX tube failure. The drain tank serves several purposes, each of which is described. The drain tank primarily provides a safe storage for the fuel salt under conditions where heat removal is assured. The drain tank also provides a number of other important functions that are primarily related to the interface between the primary system and the end-of-cycle chemical processing systems. The short-term holdup volume for fission product off-gases is also provided by the drain tank. In many ways, the drain tank is at the center of the chemical processing systems and rivals the reactor vessel in size, complexity, and importance to operations and plant safety.

The MSBR drain tank was sized to contain 70.8 m^3 of fuel salt. This volume was sufficient to contain all of the fuel salt volume plus an additional 45% contingency. The average power density corresponded to 46.1 MW/m^3 with respect to fuel-salt volume. The volume of fuel salt in the ABC is estimated to be 15 m^3 (47.4 MW/m^3), with about 30% of this in the core at any one time. Allowing the same contingency volume in the drain tank, the tank must have a storage capacity of 22 m^3 . This corresponds to about one-third the volume of the MSBR drain tank. The height remains the same at 6.71 m. The diameter of the tank is 2.4 meters. The result is a tall, thin tank. Retaining the same height, however, allows the entire passive cooling system to be adopted from MSBR(???). A set of parallel LiF-BeF_2 circuits are used to remove the decay heat in the drain tank passively. The LiF-BeF_2 circuits are in turn cooled by parallel water/steam loops.

c. Off-Gas Handling

The MSBR design includes a complex off-gas collection system. The primary purpose of this system is to remove volatile fission products, the most important of which is ^{135}Xe , from the fuel salt to increase the breeding ratio. Because of the small margins available in thermal breeding, reductions in the parasitic neutron losses were essential for the MSBR design.

The MSBR off-gas system design incorporates three delay zones and a final cleanup system. The first delay zone was the gas space in the fuel-salt drain tank. The heat load

from the volatile fission products was used to maintain natural circulation in the drain-tank heat-removal system at all times. After decaying for two hours in the drain-tank air space, the off-gas was transferred to a short-term delay bed that was designed to allow decay of the ^{135}Xe (9.1-hr half life). After a 47-hr holdup in this second zone, a portion of the off-gas was sent to the long-delay beds, where the decay of the longer-lived isotopes occurred. The remaining fission products were then separated from the carrier-helium in a trap and bottled for long-term storage.

A system with the complexity of the MSBR off-gas system is not needed for ABC because of the absence of the fissile-fuel breeding requirement. Furthermore, the accelerator is capable of supplying the additional neutrons would be absorbed by additional fission products not removed, albeit, at a cost of increased accelerator capacity. The accelerator-produced neutrons will not be "free" in this regard, since the cost of accelerator-produced neutrons are expected to be in the range 0.3-0.5 M\$/mole^{14,15}. Most importantly, the off-gas will be sequestered sufficiently long for the ^{135}Xe to decay. The longer-lived isotopes will be reintroduced to the primary system as part of the cover-gas system.

The off-gas system for ABC, therefore, is not as complex in comparison to that required for the MSBR. Off-gases will be stripped from the fuel salt using a bubble generator and a bubble separator that operates on a small bleed line. The separated gases will be routed to the air space in the drain tank, where they will be held for two hours. The gases will then be taken to a short-term decay bed in which they will be held for about 47 hr. Whereas the MSBR design used activated charcoal beds, zeolite would more than likely be used for ABC. The resulting mixture of helium and longer-lived fission gases will be reintroduced into the bubble generator. The net result will be a slow buildup of longer-lived isotopes in the cover gas over time. The neutronic effects of these isotopes are not expected to be large, but the operational effects are important because of the additional shielding and remote maintenance required for the cover gas system. If these additional requirements are found to be overly restrictive in the course of more detailed designs, additional off-gas processing can be included to lower the radiation and heat load from the cover gas system.

d. On-line Separations

Electrowinning (electrolytic deposition) techniques are proposed for the on-line removal of "noble metal" and zirconium fission products that are produced in the ABC system⁸. The "noble metals" were defined during the MSRE operation¹¹ as those metals that form fluorides that are less thermodynamically stable than ZrF_4 and include: Mo, Nb, Ru, Rh, Ag, Cd, Tc, and other transition-metal fission products. The electrowinning method has been used extensively in other industries (*e.g.*, in aluminum production) to yield pure metals from oxide or halide feed materials that have been dissolved in a molten salt. For the ABC application the purification of the molten salt instead of the production of a pure metal is of interest. A description of the electrochemical cell and the location of the cell in the ABC system follows.

The electrochemical cell consists of a consumable anode that is fabricated from beryllium metal and a nickel cathode onto which the "noble metals" and zirconium are plated. The reaction that describes the process is



where MF_n is a "noble metal" fluoride or Zr of valence state n and d refers to the fluoride species dissolved in the molten salt. The process is spontaneous, with the free energy difference between BeF_2 and MF_n being $\Delta F = \text{???? MJ/mole}$. In principle, therefore, the cell could be operated passively; however, it may be necessary to apply a small externally generated voltage between the electrodes to enhance the rate of mass transfer. The electrochemical potential of plutonium, other actinides, and lanthanide fission products falls between those of beryllium and lithium; therefore, these elements are not removed from the fuel salt. In addition to removing fission product metals, the cell would also provide control of the oxidation potential of the fuel salt. The oxidation potential of the fuel salt would be maintained as near to neutral conditions as is reasonable.

A detailed physical description of the cell is not available because only the fundamental operating principles have been established.⁸ Basic design criteria, however, can be described. The electrowinning cell would be located before the intermediate heat exchanger so that the possibility of deposition or plate-out of the noble-metal fission products on the IHX tubes could be reduced. The deposition of noble-metals on the heat-exchanger tubes does not present a materials problem but could reduce the efficiency of the heat transfer system, as well as increasing the difficulty of IHX maintenance. The entire cell would consist of a series of electrochemical cells so that the removal of fission-product metals could be optimized. Maintenance of the cell would consist of the periodic replacement of the anode and cathode and must be completed by remote operations. The cathode materials that are removed from the cell during maintenance procedures could be stored as the metals, or could be oxidized, blended with silica, vitrified, and sent to a storage facility in the form of glass.

e. End-of-Cycle Separations

Ultimately the fuel salt must be processed to remove the other fission product metals that have been produced by the fission process. These fission products are primarily lanthanide, alkali, and alkaline earth metals; in general, these species are highly radioactive. The end-of-cycle separation focuses on the extraction of lanthanides and also actinides from the fuel salt, so that the salt could be used in another operation cycle. Cesium and strontium are two fission products of major concern from a radiological point of view, but these elements would remain in the fuel salt and be recycled into the core. The end-of-cycle removal times are not as demanding as the on-line separation and could be accomplished using a batch process. The extraction chemistry and a brief description of the process design criteria are given.

Removing the lanthanides and actinides (*i.e.*, primarily ^{242}Pu , Am, Cm) from the fuel salt at the end-of-cycle would be accomplished by a liquid-metal/molten-salt extraction process⁸. The process was developed for use in the MSBR^{10,11} and is described by the following reaction:



where M is an actinide or lanthanide metal of valence n . The lithium concentration in the liquid bismuth is chosen so that the actinides are not preferentially extracted from the fuel

salt, but are extracted along with the lanthanides. Multiple stage extractions would enhance the removal of the actinides and lanthanides from the fuel salt. After the extraction process is complete, the alloyed lanthanides and actinides would be separated from the unalloyed bismuth by distilling or vaporizing the pure bismuth. The remaining alloys could be oxidized, blended with silica, vitrified, and sent to a storage facility in the form of glass, or the alloys could be fluorinated and fed into an accelerator-driven waste burner.²

Again, a detailed description of the extraction and distillation apparatus is not available and only the fundamental operating principles have been established.¹¹ Unlike the on-line separation process, however, the extraction process had been considered for use in the MSBR and many of the design criteria that are discussed in Refs. 10 and 11 can be applied to the ABC system. The distillation system would be a standard vacuum distillation apparatus, with appropriate changes being made to the system to accommodate working with radioactive materials.

7. Containment and Safety

The basic three-level containment philosophy adopted for ABC was illustrated generally in Fig. 4. Figure 14. gives plan and elevation views of the assemblage of the main accelerator, primary, and secondary systems described above. The compartment or cell structure used in the MSBR conceptual design is indicated, as is the secondary containment building, vertical maintenance scheme, and key containment penetrations.

The MSBR design included a full containment structure erected around the primary system; this feature was included in the ABC design. The basic philosophy applied to this design process was to provide three barriers (Fig. 4) to the release of large amounts of radioactivity to the environment. This definition was interpreted as requiring three barriers for the primary system, the chemical-processing system, and the off-gas system. In the case of the fuel salt in the primary system, the first barrier is the piping and vessel walls. The second barrier is the reactor-vessel cell boundary. Finally, the third barrier is the containment structure itself. The boundaries are similar for the remainder of the plant. The first barrier is always provided by the structure of the system (*i.e.*, piping, vessel, *etc.*), the second barrier is the cell boundary, and the third is the containment building *per se*.

The containment proper surrounding all the individual cells is of the large, dry type (????). For this containment the volume is used to ensure against failures resulting from over-pressurization. Although the maximum design pressure of this containment has not been estimated, the maximum pressure obtainable under accident conditions is not expected to be large (basis ???), and, therefore, the design pressure associated with this containment should be sufficient. The potential energy in the containment is expected to be considerably smaller than that in a standard PWR (*e.g.*, ???GJ/m³ compared to, ??? GJ/m³ for the ABC), since the molten salt in both the primary and secondary systems is operated at relatively low pressure.

Only a "top-level" assessment of the safety issues associated with the ABC system has been made. Because the details of the system have yet to be determined, an in-depth safety analysis cannot be performed. Nevertheless, safety considerations have played an important role in the development of the ABC plant layout reported herein. For example, providing three independent barriers to fission product release required isolation valves on

several of the molten-salt and steam-piping systems, as well as for the accelerator vacuum system. A secondary cooling loop on the lead target cooling system is suggested.

Even without an in-depth analysis, a number of potential safety-related issues have been identified. These issues must be addressed as part of a future, detailed design in a way that methods and configurations for dealing with these events are included in that design. The following events/transients have been identified as requiring additional study: target-window failure; steam-generator-tube rupture and propagation; IHX-tube failure, steam-line failure within containment; primary-system rupture; criticality excursion (*e.g.*, caused by condensation/concentration of fissionable material); core blockage; loss of heat sink; loss of target cooling system; and failure of fuel-salt drain system. Most of these events were considered during the ABC Plant Layout Study, and to varying degrees means of dealing with these events have been indirectly and individually included. Further work is needed, however, to assess the potential for combinations of these events, and the ability of the system to respond to multiple failures.

8. Instrumentation and Control

A significant development effort will be needed to provide the necessary instrumentation methods and control systems to allow characterization and precise control of the ABC blanket under all normal and off-normal conditions. While this development appears to be straightforward, only limited development has been performed in this area. The MSRE¹¹ relied on batch sampling to characterize the fuel salt during operation. While this remains as a backup option, on-line measurement of the relevant fuel-salt properties such as constituent concentrations and REDOX potential is attractive for the system.

The requirements and outstanding issues in the I&C area, as summarized for the MSBR conceptual design, generally apply to the ABC with only minor modifications. Introduction of the accelerator-generated neutrons may complicate the neutronics monitoring, especially since k_{eff} for the system must be maintained below some nominal level (0.95-0.98). Instrumentation and control is recognized as an important subsystem of the ABC system below some nominal level (0.95-0.98). While I&C is recognized as an important subsystems, the issues appear to be developmental and not insurmountable. The development and reliability of on-line chemical analyses needed for the second-by-second control of ABC power input and output, however, is expected to present some challenges to the process and control engineer. Likewise, the control of the accelerator in a system of four thermally independent blankets driving four independent thermal-to-electric conversion systems in a way where the loss of one Target/Blanket system does not cause the entire ABC system to go off line presents additional control challenges.

IV. KEY ISSUES

The main role of the ABC Plant Layout Study is to identify global issues for the ABC approach to plutonium disposition and parallel electric-power generation prior to the initiation of a preconceptual design. Only the existence of the detailed preconceptual design of the MSBR^{10,11} made this study possible. The results of modifying and/or adopting key elements of the MSBR preconceptual design to the ABC mission are summarized on Table III. Top-level technical issues that have been identified in the course of the ABC Plant Layout Study are summarized in this section. Because of the nature of this study, some of the design choices and related technical issues associated with the MSBR may have inadvertently and unnecessarily been translated into the ABC design; when possible, alternative approaches are suggested. After presenting an overview and a subsystem-by-subsystem list of technical issues, these issues are prioritized for elaboration as part of a subsequent ABC R&D Plan.⁹

A. Overview and Design Departures from MSBR

Although the ABC Plant Layout Study relied on the MSBR conceptual design study, important differences between the ABC and the MSBR designs exist. In the context of ABC and in an approximately descending order of importance these differences include: a) driven subcritical operation with a considerably enhanced flexibility in neutron balance resulting from the excess accelerator-produced neutrons and no requirement to breed fissile fuel at a prescribed rate; b) a chemical-processing philosophy that emphasizes physical separations (*e.g.*, gas-liquid, precipitation, plate-out and/or electrowinning) over chemical separations (*e.g.*, chemical extraction, REDOX); c) multiplicity of thermal-power-generating core; and d) a Li-Be fuel salt unburdened by heavy thorium loadings. For reasons related to resources or an inability to find an improved option, the ABC design retained the following key features of the MSBR: a) a strongly moderated Core consisting of ~13% fuel salt flowing through a graphite matrix housed in a Hastelloy-H vessel; b) a separate fuel-salt dump tank serving as a focal point for all elements of a multi-faceted Chemical-Processing system; c) an IHX cooled by a sodium fluoroborate secondary coolant salt; d) a generally vertical maintenance scheme for all Primary- and Secondary-System components into an overlaying Containment and/or Hot-Cell Room(s); e) a supercritical-steam power-conversion system; and f) a tertiary containment system based on a combination of operational cells or rooms (Primary System, Secondary Coolant System, Steam Generator) housed in a Containment Building and interconnected with Main Beam and Steam Isolation Valves (MBIVs, MSIVs). The ~1,000-m-long accelerator; the associated recirculating power requirement; the proton-beam transport through and bending/expansion within the Secondary Containment Building; the delivery of that beam through a thin and relatively delicate window to a spallation/evaporation neutron-generating target located centrally in the graphite/molten-salt/plutonium blanket; and the need to shield for deeply penetrating high-energy neutrons all top the list of unique technical features (and challenges) of the ABC approach to plutonium disposition.

The technical selection and winnowing of the MSBR features and the subsequent adaptation to define the unique features of the ABC has led to the particular (skeletal) design and plant layout describe in Sec. III. This design is not optimal, but, given the resolution of key (outstanding) issues, this design can with equal probability be made workable. The following section describes for each major ABC subsystem these technical issues in generally qualitative terms. An approximate prioritization of the main technical

issues, as well as directions for improved ABC designs based on subcritical, fluid-fuel approach and the benefits this approach portends (Table I) are addressed in the following subsections. This technical issues are summarized and prioritized in Sec.III.C., for use in developing an ABC R&D plan.⁹

B. Main Subsystems

1. Accelerator

The 800-1,000 MeV linear accelerator used to provide the 0.05-0.10 A proton current on target with a “wall-plug” efficiency of 45-50% was included in the ABC Plant Layout Study only for the purpose of completeness. This component exerts a major influence on the site and BOP characteristics, as well as those of the Containment Building (Fig. 14). An assessment of the physics and engineering requirements of the accelerator, even at the level considered in the “top-level” systems diagram given in Fig. 6, however, was not within the scope of this study. The nominal parameters and approach of the accelerator required for each of the $N_{ABC} = 4$ ABC units (Table III) are well within the scope of systems being proposed and designed for nearer-term applications^{26,27}, however.

Generally, the highest technical risk for the accelerator being proposed to drive ABC resides at the low-energy front end (*e.g.*, IS, RFQ, DTL, and BCDTL or CCDTL; Fig. 6). For the blanket multiplications and beam currents envisaged for ABC (Table IV), funneling of two front ends may not be necessary, as is required in the higher-current APT²⁷, but two front ends may be desirable for purposes of increase reliability. The main issue for the high-energy accelerating structure is the efficiency with which RF power can be converted to beam power under conditions where beam scrape off ($< 10^{-8}/m$) and CCL activation (hands-on maintenance) can be minimized. The use of superconducting CCLs offers important advantages in this regard, in addition to promising increased reliability. Unresolved issues related to increased cost, increased development risk, and increased time to repair the superconducting accelerating structures, however, can be identified^{26,27}. Additionally, cost-optimal superconducting CCL designs favor increased beam energy^{26,27} with yet-to-be-resolved impacts on (increased) shielding of the more-energetic forward-scattered neutrons in the Target/Blanket system and streaming in the general direction of the crucial fuel-salt dump tank.

The physics and technology of splitting, switching, and transport of each of the N_{BLK} high-energy beamlets to each Target-Blanket assembly remains to be resolved and may harbor technical surprises with an inconvenience rather than a fundamental feasibility impact. Operational issues related to the optimal means by which to drive N_{BLK} relatively independent thermal-electric fission systems with a single accelerator and still keep them independent remains to be understood. Although not related to the accelerator, the degree to which other ABC subsystems (*e.g.*, Electric and Turbine Plant Equipment, Chemical Plant Equipment; Fig. 3) can be multiplexed (like the accelerator) to derive important cost benefits¹⁵ requires further study.

2. Target

The self-cooled lead target adopted for the ABC design is probably the most efficient and eloquent configuration available for this application. Power-density restrictions for the high neutron-flux conditions required for the ABC application, along with considerations of

complexity and lifetime, probably preclude the use of solid²⁸ neutron-spallation/evaporation targets. Although unimportant from a view point of overall energy balance, use of the secondary coolant salt to remove (and recover) the majority of the beam power from the target lead would add to the simplicity of this system. A separate (????) target cooling system, however, was adopted because of unresolved corrosion issues related to the higher lead temperature if it were cooled with the (higher-temperature) secondary coolant salt. Radiation lifetime of the target structure and the thimble structure that isolates the target assembly from the blanket is the main outstanding issue for this system. Generally, the target assembly is expected to compete favorably with the graphite moderator in the blanket in establishing Target/Blanket maintenance, availability, and waste-stream characteristics. Lastly, the strategic location of the target window; the scheme adopted for cooling this delicate item; the degree to which beam-“footprint” variability can be controlled and monitored; and the general response to beam-induced radiation damage combine to create a challenging technical issue for this system.

The self-cooled lead target was adopted for the ABC design to maximize performance while maintaining simplicity and (hopefully) minimizing maintenance. The primary issues for this system are radiation damage to the structure (especially the window) and the structural corrosion caused by the lead. Other important design and operational issues are attributable to uncertainties associated with heat removal issues because of the poor wetting characteristics of the lead and the related uncertainties in both predictions with regard to structural cooling as well as design of the heat exchanger, including selecting the secondary coolant. The majority of these issues can only be resolved through experimental efforts. A variety of design options can be envisaged, as discussed in Sec. IV.D.1., but these options invariably result in a trade-off between technical difficulty and overall performance.

3. Primary System

The Primary System design for ABC follows as closely as possible that of the MSBR. The Primary System is perhaps the most important system in the ABC plant, since it contains the majority of the radioactive material. The primary system, as described in Sec. III.B.3., consists of those components that contain an appreciable quantity of fission products. For the MSBR design, a number of outstanding issues related to the primary system were identified¹⁰; these issues are discussed in the following subsections.

a. Core

The Core design was taken almost directly from the MSBR design, in so far as the moderator, fuel-salt, reflector, and vessel components are concerned. The power per Target/Blanket (Core) module was scaled down from 2,250 MWt to 711 MWt, the height-to-diameter ratio was increased slightly, and the central target was added. The use of individual graphite stringers (*e.g.*, internally moderated configuration) was adopted in the course of the trade-off between simplicity (*i.e.*, the externally moderated configuration and reduced graphite waste) *versus* vessel lifetime and available design detail (*i.e.*, the internally moderated MSBR-like configuration); this issue is addressed by neutronics computations in Appendix E. Specifically, differences in dpa rate and increases in plutonium inventory needed to maintain a constant power (*i.e.*, k_{eff}) blanket over a 12-(full-power) year operation are reported (Appendix E, Figs. E-6, and E-7).

One of the most important issues with respect to the Core design is the absence of experience with the ABC fuel salt that is a different fuel salt than that used in the MSBR.

The MSBR fuel salt contained a large quantity of thorium, which increased the density and changed the physical properties from the base LiF-BeF₂ salt. The plutonium-bearing fuel salt for ABC is similar to the basecase fuel salt use in the MSBR design, since the plutonium fraction is less than one percent. The ABC fuel salt, therefore, can be considered a LiF-BeF₂ with a plutonium impurity.

A large experimental effort will be required to develop an equivalent knowledge base for the plutonium fuel salt used in the ABC design. From the standpoint of fluids and heat transport, the differences between pure LiF-BeF₂ and salt containing plutonium, however, are not significant. For corrosion and salt stability, significant differences may exist. Tests will be required to quantify plutonium solubility in the fuel salt, both with and without fission product impurities. Some of the rare-earth fission products may compete with plutonium to an extent where plutonium solubility in the salt is reduced.

Another facet of this fuel salt experimental program would focus on determining the physical properties to an extent needed by a detailed thermal-hydraulic design of the Primary System. As noted, the values for pure LiF-BeF₂ were used in this study.

The graphite moderator presents a second important issue for the ABC Core. The graphite is a problem primarily because of a potential to generate high level waste over the course of its lifetime, and disposal of large volumes of fission-product-contaminated material may be problematic. As discussed in Appendix E, designs have been developed that limit the graphite in the core. These externally moderated core concepts shift the design problem from one of (contaminated graphite-moderator) waste generation to one of reactor vessel lifetime (a waste of another kind). Although the relative difficulty of the contaminated-moderator *versus* reactor-vessel waste problems in terms of volume and intensity remains to be resolved, the central issue is the feasibility of frequent reactor-vessel replacements and the need to maintain the $p_f = 0.75$ plant availability. Although the neutron spectrum for the externally moderated concept is somewhat harder than that of the internally moderated system, the significant difference in size between the two (the former is smaller) results in large increases in average flux for the externally moderated option. This configuration projects a vessel diameter of only 1 m (compared to 3.5 m for the MSBR-like internally moderated configuration), which, for the same level of total fission power, results in a substantially larger (total and fast) average neutron flux. Ultimately, an operational and cost (*i.e.*, replacement cost, availability, waste stream, etc.) trade off must be resolved that centers primarily on the average core power density and the core or reactor-vessel lifetime. Intermediate use of graphite in both the fuel-salt region and as a reflector placed between the fuel salt and the reactor vessel represents an option in need of future (thermal-hydraulic, neutronic) optimization computations, some of which are reported in Appendix E.

The degree of (credible) inherent safety of the ABC core related both to reactivity insertions and to loss of cooling represents a second important design issue for the core. Since the impact and fate of most of the afterheat is intimately related to the fate of the fluid fuel (*e.g.*, use of freeze plugs and a passively cooled dump tank¹⁰), attention was focused more on the former and the reactivity temperature coefficient (RTC). Preliminary computations indicated that the Beginning of Life (BOL) RTC for the internally moderated core design was (undesirably and unlicensably) positive; unlike the ²³³U-fueled MSBR, a low-energy fission cross section in ²³⁹Pu is experienced as the core temperature increases, and the resulting power spike that results in passing through this resonance is thermal-

mechanically unacceptable. It was this finding that led to the exploration of the externally moderated concept for ABC; the somewhat harder neutron spectrum aligned more favorably with the fission resonances in ^{239}Pu to give a negative RTC at BOL (???)\$. At this stage in the ABC blanket scoping study, it is not clear whether resonantly absorbing fission products will rapidly force the RTC negative irrespective of the BOL fuel, moderator, or general neutronics condition. As a compensating feature, burnable resonance absorbers, such as gadolinium or erbium, can be used to force a negative RTC at BOL. Although of initial value, the kinetic character of the core as a function of exposure may make use of burnable poisons throughout operation difficult, depending on whether such additions are competing with plutonium solubility or are being removed by the chemical-processing system.

The present APC Plant Layout Study made a choice of in-core fuel-salt fraction that favored reactor-vessel longevity over simplicity of Core design and reduced graphite/fission-product waste stream. A fully moderated Core design, therefore, was assumed, and the graphite disposal problem (*e.g.*, the added chemical processing required to reduce the contamination of the damaged graphite) will be dealt with later in the detailed design. The graphite lifetime exerts a strong impact on the quantity of material ultimately produced, but in magnitude has yet to be quantified for the ABC design. The graphite lifetime is a direct function of the neutron flux intensity and spectrum in the core, which in turn is a function of the plutonium loading, the fission product removal time, and the fuel salt/graphite core fraction (*i.e.*, degree of moderation). These core design used in this ABC Plant Layout Study was taken from the MSBR design, and has not been fully evaluated in the context of the ABC mission. Even the MSBR core design was described¹⁰ as a preliminary design and subject to change in the course of a detailed design. It is expected that more detailed neutronic calculations will indicate improvements to the core design.

b. Fuel-Salt Pump

The fuel-salt pump design was taken unaltered from the MSBR design (Fig. 9). Since the pump design was not scaled back from the MSBR requirements ($1.0 \text{ m}^3/\text{s}$ versus $0.55 \text{ m}^3/\text{s}$), the result presents a conservatively large footprint for the ABC Plant Layout. During the MSBR design effort, the pump design was not considered an outstanding issue. The only concerns relating to the pump design were scaleup of the pumps from that used in the MSRE¹¹ to the size anticipated for MSBR. The pumps required for either the MSBR or the ABC are much larger than the largest (molten-salt ???) pumps that have so far been operated. The design is similar to those used in the past, but scale-up problems should be expected with such a large (\times ???) pump increase in scale. An additional problem for the ABC application is the loss of expertise that was available in this area over three decades since the MSBR activity concluded.

c. Intermediate Heat Exchanger

The IHX design is non-standard, with the intention to accommodate remote maintenance easily. The ABC is scaled from the MSBR design (Fig. 10), with a few modifications being made. Outstanding issues from the MSBR design remain, however, and are related primarily to the heat-transfer correlations used to size the IHX. Experiments that include large-scale tests, are needed to verify these correlations. Also, the individual tubes were knurled to increase the surface area and to enhance the heat transfer. The anticipated improvement has not been verified experimentally. These uncertainties, however, portend

no "show-stopper" issues, since the size of the IHX can be increased to accommodate any design shortfall. Any increase in the IHX size, however, will increase the fuel-salt volume and reduce the in-core fraction; for the present ABC Plant Layout, 99.9% of the total fuel-salt inventory resides in the IHX.

4. Heat-Removal (Secondary) Systems

The Heat-Removal systems together form a number of outstanding issues. While the secondary coolant salt has some useful features, it also introduces a number of difficulties. These issues are not unique to the ABC application^{10,11}, but nonetheless must be addressed. Also, the design of the supercritical-steam system needed to take full advantage of the (high-temperature) molten-salt primary coolant is somewhat advanced. The SCS system presents a number of associated issues that remain to be addressed.

a. Secondary Coolant Salt

Sodium fluoride - sodium fluoroborate eutectic is the reference secondary coolant salt. This eutectic combines good thermal-hydraulic properties with low cost. This material, however, is not easy to handle, since during operation it decomposes thermally with the evolution of BF_3 . The BF_3 gas must be reintroduced into the coolant-salt loop to avoid changes in the overall properties of the salt; a complex cover gas system, therefore, is required.

Other secondary coolant salts have been proposed including LiF-BeF₂, HITEC (NaNO_3 - KNO_3 ???), and Li-Be-Zr-F. While each has some advantages over the sodium fluoroborate, none were determined to be better on an overall basis. The fluoroborate salt is probably the best characterized. Other coolants including liquid metal and helium, have been suggested, but as with the range of molten-salts considered, none was judged to be as good as fluoroborate.

Another consideration that has to be taken into account in choosing a secondary coolant is trapping of the tritium generated in the course of fission and from neutron reactions with the lithium-bearing fuel salt. The sodium fluoroborate has been shown to trap greater than 90% of the tritium introduced under steady-state conditions. None of the other secondary coolants, with the exception of helium, has this capability. At the proposed operating temperatures (900 K), tritium readily diffuses through Hastelloy-N. It is expected that the majority of the tritium will migrate into the secondary coolant system through the thin-walled IHX tubes. This tritium must be prevented from reaching the steam system, since further containment cannot be assured (e.g., contamination of the turbines is to be avoided). The sodium-fluoroborate coolant salt offers a potential for tritium trapping and removal. The mechanisms responsible for the trapping, however, are not understood. The MSBR project was canceled prior before investigations into the mechanisms could be completed. Before this trapping can be reliably invoked by the ABC design, an experimental program that is combined with material compatibility tests are essential.

Material compatibility tests are needed to settle another outstanding issue. The corrosion rate of the reference construction material for the entire secondary coolant system, Hastelloy-N, in fluoroborate salt is low. In the presence of moisture, however, the corrosion rate increases dramatically. Corrosion is primarily a concern for pinhole leaks or cracks in the steam generator or reheater tubes; massive failures, although to be avoided, would be easily detectable, while small leaks might introduce moisture for some time

before being discovered. Tests will be necessary to determine the corrosion rates of Hastelloy-N under various moisture levels in the sodium-fluoroborate. Analysis will be required to determine the allowable moisture concentration. Finally, if the allowable moisture level is too stringent, additional moisture removal capability will have to be designed, or duplex tubing will be required in the steam generator and reheater.

b. Supercritical-Steam System

The supercritical-steam system is advanced, but the design can be readily extrapolated from the state of the art. The design adopted by the ABC Plant Layout Study is taken MSBR design, which was in turn adapted from the Bull Run Steam Plant²⁵. The Bull Run plant is coal fired, but otherwise has the same steam conditions as adopted for the ABC. Operation with supercritical-steam system is complicated by the feedwater requirements that in turn is dictated by the use of fluoroborate. To prevent freezing of that coolant salt in the heat exchangers, the minimum feedwater temperatures have been set to 618 K (650°F) for the reheater (Fig. 12) and 644 K (700°F) for the steam generator. High (???) quality steam is first bled from the steam-generator outlet to generate this high temperature. The main outstanding issues for the steam system are the heat transfer in the heat exchangers and design of the reheat steam preheater.

Tests will be required to assure that either freezing does not occur in the steam generator or reheater under normal and transient conditions, or that freezing is not detrimental to the equipment. The tests will be similar for both pieces of equipment, with only the steam conditions differing.

To provide final feedwater heating, the first (???) quality steam exiting the reheat-steam preheater is blended directly with the feedwater. In a subcritical-steam system, this mixing would produce violent (mechanical) reactions from bubble collapse. For the supercritical system, however, the two phases are indistinguishable, and mixing may be accomplished in large spherical drums, as is done at the Bull Run power plant. If the reference design is changed to a subcritical-steam system, experiments will be required to verify that mixing can be accomplished without damaging the equipment.

The reference ABC design calls for a each Target/Blanket module to be serviced by an individual turbine plant of capacity 280-319 MWe. This arrangement may not be the most cost-effective for the for the overall $N_{BLK} = 4$ ABC system. Cost-based parametric studies¹⁵ are needed to assess the optimal BOP configuration in this regard, and the operational impact and flexibility of operating with more independent units. Since all four units are driven by the same accelerator, control issues related to the desire to achieve the highest availability for electrical output are identified.

5. Chemical Processing

The chemical processing requirements for the ABC and the MSBR systems are different. Chemical processing is perhaps one of the least defined elements of the ABC design. The basic requirements have yet to be defined, since neither the necessary neutronic (burnup/burnin) analyses nor chemical transport/processing have not been performed. Basic information, however, is available to provide focus on the outstanding issues. While many of the processes are similar to those anticipated and modeled as part of the MSBR conceptual design,¹⁰ the emphasis in chemical processing for the ABC has been driven primarily by the goals of increased simplicity and waste minimization. This shift in

emphasis has been driven primarily by goals of increased simplicity and waste minimization. At the present state of ABC concept development, a number of generic issues generated from a perspective of the the above differences can be identified and described.

First, determinations are needed of the removal rates for off-gases and insoluble fission products for a fuel salt that has significant differences from that used in the MSBR design. These rates are determined by neutronic and thermal-physical considerations, as well as sizing considerations for the chemical processing equipment.

The primary concern of the chemical-processing design should be the determination of the required reprocessing rates and equipment sizes. If a batch fuel cycle can be accommodated at a frequency that is neutronic and operationally acceptable, only limited on-line processing will be required. If, however, the required removal time is short, extensive chemical processing development will be required.

One of the early design drivers for the MSBR fuel reprocessing was separation of ^{233}Pa from the fuel salt so that decay to the ^{233}U fuel could occur outside the competition of the neutron environment. Because thorium plays no role in the ABC, this design driver is not an issue. Instead, the level of parasitic neutron absorption as it impacts both the efficiency of plutonium disposition and the need for added accelerator capacity, along with solubility limits, inventories, and activity control, are key design driver for the ABC. Plutonium solubility limits are also an issue. The lanthanide fission products compete with plutonium for fluoride ions and cause a reduction in the amount of plutonium that can be held in solution, thereby impacting reactivity (burn up) limits.

Another chemical processing issue revolves around the off-gas system requirements. As with the soluble and insoluble solid fission products, the neutronic impact of the gaseous fission products have not been assessed. Some level of off-gas processing will be required to strip the fission products from the helium cover gas. Once the requirements for this system have been determined, a number of issues become important. It is known, for example¹⁰, that the off-gas cleanup equipment can be large (e.g., activated carbon filter beds) and will require a large amount of floor space within the containment volume. The chemical processing equipment may lead to an increase in the containment size, which represents primarily an economic rather than a technical issue.

Regardless of the degree of fission-product removal that is eventually required, a minimum amount of equipment is required to prepare initial and make-up batches of fuel salt, and to cleanup salt after an off-normal situation such as a steam-generator tube leak or an IHX tube leak. The flowsheets for these operations need to be developed. Fission-product removal and cleanup is an outstanding issue because the sufficient floor area must be provided for these operations within an otherwise expensive and congested containment volume.

6. Operations and Maintenance

Operations and Maintenance is considered an outstanding issue, particularly in view of uncertainties of target-structure, graphite-moderator, and reactor-vessel radiation lifetimes. The design of the ABC allows for all components having an expected lifetime shorter than that of the plant can be replaced in a time required to assure the design plant availability

factor ($p_f = 0.75$). Many of these components will require remote maintenance because of fission- and activation-product contamination. The containment cells and buildings (Fig. 14) were designed with spacings between components sufficiently large to accommodate expected maintenance operations, as well as uncertainties in estimates of component sizes.

Additional laydown area and/or maintenance clearances may be required for remote-maintenance operations and should be identified early in the ABC design process. These issues, while not in the class of "show stoppers", greatly affect the component layout, cell and building volumes, and (ultimately) cost.

An operations plan is needed to identify undefined equipment needs and to complete key remaining holes in the design. For example, refueling the system will require an interface with the Primary System *vis-a-vis* the fuel-salt drain tank and the Chemical-Processing systems. Graphite-moderator and lead-target replacement equipment must be considered.

7. Instrumentation and Control

With the exception of Chemical Processing, the I&C system is most in need of definition. The I&C requirements of the MSBR design were reviewed as part of the ABC Plant Layout Study. The requirements for ABC in this area are similar to the needs anticipated for the MSBR, but important differences can be identified. Because of advances in I&C methods and technology since the completion of the MSBR program over three decades ago, the entire I&C system will require redefinition. Additionally, both the safety, neutron-economy, and Chemical-Processing complexity and waste-stream issues are expected to be relaxed for the ABC compared to MSBR.

Monitoring equipment is needed to provide fast-response and multiple point information on temperature, pressure, fluid levels, composition, moisture content impurity levels, plutonium concentration, REDOX potential, *etc.* Several of the required capabilities were never developed by the MSBR program. For example, fuel-salt composition measurements had to be made by taking samples followed by exo-reactor analysis. This method was slow, and its use would dramatically affect operations and safety procedures.

Another I&C issue is the neutron monitoring in the presence of the target spallation source. Methods of monitoring k_{eff} must be developed and verified for the subcritical ABC operation. The SCRAM system has also not been designed, other than the recognition of a need to incorporate shutdown (and possibly control) rods into the Core design. The applicability of chemical "shims" on a widely variable time frame, as well as the monitoring of local power densities and temperatures within the Core present important I&C challenges.

A shutdown system has to be defined. Signals that will require a module shutdown remain to be determined. Likewise, the means by which startup, approach to full power, the long-term control of power output and spatial power distributions, and both the short-term and long-term of the Target-Blanket system and the Primary System in general in the hot-standby condition remain to be resolved. These I&C requires are primarily design rather than technology issues, however.

8. Containment and Safety

The safety philosophy used for advanced fission-reactor designs was adopted for the ABC Plant Layout Study. As is shown in Fig. 4, three barriers encompass all potential radioactive source terms. A full containment building was provided, even though a passive fuel isolation and cooling system (drain tank) is incorporated into the ABC design. Much additional effort will be required to identify the key accidents, and to assess the systems ability to deal with these accidents. This effort, however, must focus onto containment of the accelerator *per se* and prevention and/or mitigation of fluid and pressure transmissions between the main cells and buildings that comprise the ABC plant.

V. CONCLUSIONS AND RECOMMENDATIONS

A preliminary plant layout has been developed for a molten-salt-based ABC using as much as is possible and appropriate the detailed design and optimized results reported for the Molten-Salt Breeder Reactor conceptual design^{10,11}. The main goal of this ABC Plant Layout Study is the identification of key technical issues for the ABC approach to weapons-plutonium disposition on the basis of a pre-conceptual design layout of key non-accelerator components. A secondary, but nonetheless important, goal of the ABC Plant Layout study is the identification of design options for a molten-salt-based ABC concept that would be appropriately used by a future ABC conceptual design. This section on conclusions and recommendations summarizes key technical issues and alternative design options for ABC.

A. Ordering of Key Issues

Although the Accelerator Equipment was included for reasons of completeness in this ABC Plant Layout Study, the identification and ordering of key technical issues for elaboration in an ABC R&D plan⁹ is limited in this study to the Target, Primary System, Heat-Removal (Secondary) System, Chemical Processing, Operation and Maintenance, Instrumentation and Control, and Containment (Safety). Research and Development issues for the high-power (capacity), high-current (efficiency), and necessarily reliable (multiplexed Target-Blanket assemblies) accelerating structure, however, can not be minimized. The focus here, however, is on issues not related directly to the Accelerator Equipment, albeit, important interfacial issues and influences (Fig. 4) exists.

The MSBR conceptual design had been an essential element in defining all non-accelerator ABC plant components. In establishing a priority list of key technical issues for the molten-salt ABC, it is helpful to begin with a brief revisit of important technical issues raised by the MSBR conceptual design. While the MSBR has been considered a "chemist's dream", some aspects of that program might also be considered a "materials dream". None of the problems unveiled by the MSBR experience were considered to be "show stoppers" or "fatal flaws", with the possible exception of stretched doubling times caused by the pull of marginal neutron economics and the impact thereon of fission-product buildup related to uncertainties in the chemical-processing effectiveness. The main problems encountered during construction and operation of the MSRE and left unresolved at the time of the MSBR project closure were related to materials: a) radiation-induced helium embrittlement of the Hastelloy-N structural material; b) containment of the significant quantities of tritium formed (primarily) from neutron captures by lithium; and c) grain-boundary attack in the Hastelloy-N structural material by tellurium fission product. Solutions to these problems were left in the legacy of the MSBR program: a) immobilization of helium in Hastelloy-N by carbide precipitates; b) reduce tritium production by selection of an alternative fuel salt; and c) adjust fuel-salt REDOX potential to maintain the tellurium fission product in solution. While these singular solutions to singular problems encountered by the MSBR project do not provide global assurances that the materials problems for molten-salt systems are resolved, steady progress of this kind is encouraging.

In laying out and ordering the key (non-accelerator) technical issues for ABC, it is appropriate to begin with a general statement of materials requirements, particularly as they

may differ from the MSBR experience. These general chemical and radiation-effects materials limitations impact all life-time (plant-availability and operating-cost) and waste-stream (target structure, graphite moderator, Primary-System structure, fuel salt) performance measures of ABC effectiveness. Key technical issues related to specific ABC subsystems then are listed in descending order of priority according to: Target; Blanket; Chemical Processing; key non-blanket Primary-System components; Secondary and Balance-of-Plant systems; and Containment and (related) Safety systems.

1. Materials and Fuel-Salt Chemistry

Since material and chemical issues are identified with all of the main ABC subsystems, these are first described as a generic class at the top of the of ABC technical-issues list. As summarized above for the MSBR, materials requirements and uncertainties associated with the Primary System and Chemical Processing also are expected to present a dominant concern for the molten-salt ABC. The differences in the fuel-salt composition and associated REDOX potential, however, are expected to lead to important differences in materials problems, even if the "tried-and-true" Hastelloy-N alloy is used also as the primary containment material for ABC. While the solutions to the Hastelloy-N problems described above for the MSBR may also apply to a fuel salt with the dominant PuF_3 species present almost at impurity levels and without heavy loadings of thorium, the control of tritium, gaseous fission products, and noble-metal (low-solubility) fission products through on-line processing and off-gas control is ranked as the top issue for the non-accelerator part of ABC. In addition to the control, removal, and collection of insoluble gaseous and noble-metal fission products, the control of soluble fission products (*e.g.*, lanthanides), and the impact on both the neutron utilization (*i.e.*, accelerator capacity and operating cost) and post-irradiation fuel-salt remediation and disposition define crucial operational, safety, and waste-stream issues for ABC. The degree to which long-lived and/or strongly parasitically absorbing fission products are incorporated into/onto frequently replaced graphite core components determines both the overall neutron economy and the level of post-irradiation cleanup and the eventual classification of this potentially large-volume waste stream. Ranked close in importance with these chemical-processing issues is the control of plutonium (and actinide) solubilities in a system where the plutonium-inventory requirement can vary by factors of 5-10 over the life of irradiation (Appendix E, Fig. E-4). Hand-in-glove with these issues is that of Hastelloy-N (or other alloy) compatibility under high-radiation conditions combined with wide variability of chemical environments throughout the ABC primary system.

2. Main ABC Subsystems

a. Target

Along with the Accelerator Equipment, the Target has no MSBR counterpart. The self-cooled, liquid-lead target and associated (niobium alloy) window and structure operates at the highest heat flux (????? MW/m²), power density (???? MW/m³), and (high-energy) neutron flux ($???\times 10^{20}$ n/m²/s). The target performance is central to the overall efficiency (primary neutron yield, blanket neutron coupling) and availability (mean-time-to-failure and mean-time-to-replace) of the ABC. Residing operationally and physically at the interface between the accelerator and the plutonium-bearing fluid-fuel blanket in a high-importance region of that blanket, the target performance is critical to all operational and

safety facets of ABC. The main technical issues associated with the application of this high-performance liquid-metal target system include:

- target material choice as related to neutron production efficiency, operating temperature, chemical compatibility (in a changing chemical environment), radionuclide production, waste generation;
- development and demonstration of an engineering configuration that assures reliable operation under high heat- and neutron-flux conditions, high-power-density operation, high thermal-mechanical stresses, and in a cross-roads environment that is central to achieving an acceptably safe, efficient, and cost-effective ABC.
- development of chemical and thermal-mechanical monitoring systems, secondary cooling systems, and single-unit remote replacement systems that assure design safety and availability standards/goals under the anticipated conditions of relatively short operational longevity of this key-stone system.

b. Blanket

While the ABC blanket configuration has been adopted largely from the MSBR design, important materials and fuel-salt differences listed in Sec. V.A.1. contribute to related issues in need of resolution. Furthermore, most of the technical issues listed above for the Target apply directly to the Blanket, particularly as related to radiation longevity, thermal/mechanical/neutronic diagnostics, reliability/availability/maintenance/inspectability (RAMI), and post-irradiation cleanup and waste-stream generation. An important issue is the degree to which the MSBR-like configuration can be re-optimized to give a simpler, reduced-waste, and increased-life ABC blanket while maintaining most of the important attributes of the MSBR approach. The material reported in Appendix E gives preliminary neutronic results on an "externally moderated" molten-salt configuration wherein the amount of graphite in contact with the fuel-salt is considerably reduced. While the Blanket is central to the fissioning of plutonium and the associated power generation, in the present design, it contains only ~30% of the active fuel salt (and associated plutonium and fission-product inventory); as important as is the Blanket, functionally, it is only a part of the overall transmutation(fissioning)/chemical-processing system.

c. Chemical Processing

Most of the issues listed in Sec. V.A.1. pertain directly to the Chemical Processing system. In addition to control and collection of gaseous, noble-metal, and soluble fission products, as well as the time-varying plutonium concentration and the distribution of that concentration throughout the Primary Systems, Chemical Processing encompasses issues related to: plutonium feed preparation and injection; b) preparation of separated fission products for either disposal or re-injection into the Primary System; and c) remediation of all fuel salt into a "standard" waste form that is acceptable for geologic disposal. The fuel-salt dump tank played a central role in the Chemical-Processing system suggested by the MSBR conceptual design, and this central role remains in the adaptation to the ABC. In terms of fluidonic functions and scope, the dump tank is significantly more complex than the blanket, albeit, the power and neutron loads are considerably reduced. When combined with the scheduled (operational) and unscheduled (accident) use of the fuel-salt dump tank, this system takes on an importance equal to that of the Blanket *per se*. Hence, the scope of

the Chemical Processing systems includes the Primary System and the fission-product separation/collection systems appended thereto, and the function of the Chemical Processing system occurs in parallel and in conjunction with that of the Primary System; they are inextricably mixed. Key technical issues related expressly to the former are:

- a chemical diagnostics network is needed that, working in conjunction with the thermal-hydraulic, thermal-mechanical, and neutronic monitoring systems, can give an accounting of all active and passive radioactive inventories throughout the Primary System and appended Chemical-Processing systems;
- demonstration of all chemical preparation (plutonium injection and fission-product re-injection), separation, and collection unit operations (*e.g.*, gas sparging, tritium barriers, zeolite storage, electrowinning, reductive extraction, *etc.*) at a scale that is relevant to ABC for both Primary System and Target cleanup;
- development and demonstration of post-irradiation cleanup and waste packaging of from Target (spallation and corrosion products, windows, thimbles and structure), Blanket (graphite, reactor vessel), zeolite beds, electrowinning plates, and used fuel salt;
- detailed design and simulation of all combined operational and safety functions of the interactive Primary-System and Chemical-Processing components.

d. Primary System

The essential elements of the Primary-System technical issues have in one form or another been covered in the previous sections on Target, Blanket, and Chemical Processing; these systems are inextricably mixed and share many technical issues related to component longevity, waste-steam generation, operational efficiency, and safety. Aside from the above-listed items, the remaining Primary-System components have been taken directly from the MSBR conceptual design, and the main technical issues related to these reflect the need for technical risk reduction and the related need to develop prototypes. In this category are included the following Primary-System components: fuel-salt pump; molten-salt valves; molten-salt (IHX) and liquid-metal (target) heat exchangers; fuel-salt drain systems (tanks, melt-plugs, piping, gas-transfer systems, and valves); fresh fuel-salt injection; remote maintenance schemes for a wide variety of radioactive and interconnected fluid systems; instrumentation and control of a wide variety of nuclear/chemical/thermal-hydraulic fluid systems; Primary System boundary systems, including thermal insulation (if the MSBR "furnace" concept is adopted) and interconnections with the secondary and tertiary (containment building) containment volumes. While each of these components can with acceptable confidence be designed and operated alone, important steps in overall risk reduction associated with the interactive complexities of integrated operation are needed.

e. Secondary and Balance-of-Plant Systems

The Secondary and Balance-of-Plant systems include all non-accelerator components beyond the shell side of the IHX. These systems have been scaled directly from the MSBR conceptual design, and the technical issues related thereto remain identical:

- tritium mitigation (elimination of lithium from the neutron environment) and/or containment (diffusion barriers in IHX);

- impact of supercritical-steam (SCS) power-conversion on (need for) reheater and steam-generator (SG) design, as well as impact on the SG cell layout needed to accommodate steam-tube failures;
- general cost-effectiveness of increased complexity of the SCS conversion system *versus* the increased thermal-to-electric conversion efficiency;
- choice of alternative (lower-melting) secondary coolant salt.
- operational and cost tradeoffs related to number *versus* size/capacity of SG, SCS lines and MSIVs, Turbine Plant Equipment, Electric Plant Equipment, and Miscellaneous Plant Equipment.

An number of unique features of the multiple Target-Blanket ($N_{BLK} = 4$) feature of the ABC application create issues for the SHT/BOP system that were not encountered in the MSBR design. These technical issues revolve primarily around the nature of multiplexed operation and the need to maintain constant accelerator-power input and near-constant electrical-power output in event of the loss of one Target-Blanket module. Just as multiplexing of a single accelerator represents an essential economic/technological compromise in the operation of the ABC power plant, similar techno-economic tradeoffs may exist with respect to CPE and SHT/BOP systems; these tradeoffs require future elucidation.

f. Containment and Safety

Although a traditional three-tiered containment philosophy was implemented in the ABC Plant Layout Study, a number of technical issues have been identified. These issues include:

- any surface containing fuel salt is generally defined as the primary containment boundary, and at some level is considered analogous to the fuel-pin cladding in a conventional fission power plant. This analogy requires further examination, since in the case of the fluid-fuel system, a "cladding failure" can result in the ejection of an appreciable fraction of the fuel inventory into the secondary containment (*e.g.*, the Target- Blanket cell) or beyond;
- the diffuseness of the primary containment boundary requires considerably more design definition before containment integrity and the extent to which "single-point" failures can contribute to the extent and frequency of containment-boundary violation;
- the size and multiplicity of interconnectivity between containment boundaries and the method of isolation in event of an inner-boundary violation requires resolution; the (high-pressure) SCS system requires a larger number of MSIVs, and the accelerator beamlet line serially penetrates all three containment barriers with the need for a series of fast-acting beam (accelerator) isolation valves;
- frequent target maintenance, and possibly blanket maintenance, will necessitate routine opening of the primary and secondary containment envelopes, with the volume within the (tertiary) containment building being used to provide the needed laydown and transfer areas for large quantities of highly radioactive material; the

safety impact of the frequency, the duration, and the source-strength magnitude (albeit, most of the fuel salt is safely stored in the dump tank) of these essentially "singly confined" activities should be assessed.

B. Alternative Design Approaches (samples)

1. Target

Alternative design approaches for the neutron-producing target are numerous. A variety of alternate liquid metals²⁹⁻³¹ have been proposed, such as bismuth, lead-bismuth eutectic, lead-magnesium eutectic, and lead-tin eutectic. Although the use of these materials decreases the target operating temperature, all alternatives exhibit certain disadvantages, such as additional corrosion (bismuth, lead-bismuth), lower neutron production and higher neutron absorption (lead-magnesium, lead-tin), and small information database for use in making initial target performance predictions (lead-magnesium). Use of these alternative materials, however, should not be precluded at this point, and greater consideration would be given to these alternatives if high operating temperatures required of lead becomes a primary concern. Another possibility of limiting the effect of the high lead temperature is to remove the primary structural cooling concern (*i.e.*, the window) from the lead environment and to use an alternate coolant for this structure. That alternative raises other design issues that are outlined briefly in Appendix D.

In addition to considering alternative liquid-metal candidates, the target solid target designs using a flowing coolant offer other possibilities. The majority of neutron production for these configurations would occur in the solid material, and the liquid would only remove heat. Because of the high temperatures generated in solid materials exposed to the high-energy proton beams required by the ABC system, only a few materials, such as tungsten, tantalum, and possibly thorium, can be considered for direct exposure to the full proton beam²⁸. A number of solid target designs were considered early in the ABC design, such as a water-cooled tungsten (with a secondary lead annulus) target, liquid-metal-cooled (Na,K, and NaK) tantalum or tungsten targets, and a molten-salt-cooled thorium target. While all of these targets appeared potentially functional, they all possessed characteristics, such as higher neutron absorption, greater complexity, and more severe accident scenarios, that made them less attractive than the flowing lead target.

2. Primary Coolant Systems

The main criteria for the primary coolant system in ABC are: acceptable fissile-fuel (plutonium) solubility; low pressure; and tolerably low neutron absorption cross sections in a nominally thermal spectrum. The process used for the MSBR fuel-salt selection^{10,32} identified two dozen elements that met the latter criterion. As noted in Ref. 10, compounds that qualify as permissible major constituents can be formed from beryllium, bismuth, ¹¹B, carbon, fluorine, ⁷Li, ¹⁵N, oxygen, and the fissionable elements. While many compounds can be prepared with these elements as major constituents, most have been eliminated^{10,32} on the basis of the need to form practical (*e.g.*, sufficiently low melting, stable) melts. In the case of MSBR and the associated need for high thorium loadings, the carbonates were eliminated. Nitrates and nitrites were eliminated for MSBR on the basis of thermal stability. On the basis of these broad arguments, only fluoride salts were deemed suitable by the MSBR designers for the list of neutronicly acceptable elements.

Although fluorine can moderate neutrons, the moderation power is insufficient, and an additional moderator was required in the MSBR; chemical compatibility with molten-fluoride fuel mixtures led to the choice of graphite moderator. On the basis of this broad chemical and neutronic design/selection philosophy, the MSBR core design reported in Ref. 10 was generated; this design has served with little change as a key touchstone for the ABC molten-salt concept, despite obvious differences in design constraints (Table I).

While relaxed because of the subcritical, driven, non-breeding nature of the ABC application, many of the considerations that led to the choice of molten fluoride fuel salt for the MSBR apply to the ABC. Elimination of the need for high thorium concentrations, however, along with a somewhat relaxed neutron economy and a shift from UF_4 to PuF_3 chemistry, might open other options for the fuel salt used in ABC. For each new fuel salt system that is proposed, however, many hundreds/thousands of man-hours would be required to determine plutonium solubility, physical property data, materials compatibility data, and chemical processing data for the fuel salt. The benefits of a new fuel salt, whether it is a new ternary or quaternary fluoride, or perhaps a carbonate-based system, must outweigh the amount of effort that is required to qualify the new system.

Whatever the broadened choices with respect to molten-salt chemistry for the ABC application, new primary-coolant and moderator-configuration options and variations relative to the MSBR can be suggested as areas for future work. Appendix E gives the results of preliminary neutronic parametric calculations that varied the degree to which graphite moderator is co-mingled with the fuel salt. Figures E-6 and E-7 demonstrate specifically the impact of fuel/moderator ratio and geometry on burnup capability and dpa rate (in the graphite). Movement of the moderator to the periphery of the fuel-salt zone may increase moderator longevity, reduce waste, and simplify the blanket thermal-mechanical design. Options that cool an internally circulated fuel-salt with a primary (salt) coolant that contains no fissionable material remain to be examined as a means to reduce (eliminate) exo-blanket fissile and fission-product inventories.

3. Secondary Coolant System

Several alternatives have been proposed for the secondary coolant system. The alternative that is closest to that used herein is the substitution of another secondary coolant. Suggested coolants include HITEC($KNO_3/NaNO_3$???), $LiF-BeF_2$, $NaF-LiF-BeF_2$, sodium, and helium. Each alternative has advantages and disadvantages.

The HITEC salt has a lower melting point than the sodium fluoroborate and, therefore, allows a reduction in the feedwater-temperature requirements. However, HITEC may undergo a violent reaction if contacted with the moderator graphite. The use of HITEC, therefore, would require another coolant loop positioned intermediate between the HITEC and the fuel salt. This additional complexity and reduced thermal-conversion efficiency would be somewhat counterbalanced by the simplifications allowed in the steam system. The HITEC salt may also have the capability of trapping tritium via oxidation and subsequent sequestration in the HITEC off-gas system. While not demonstrated, this tritium trapping capability would represent another advantage.

Pure $LiF-BeF_2$ was used as the secondary coolant on the MSBR and is the best coolant from the standpoint of compatibility with the fuel salt. The $LiF-BeF_2$ salt, however, has drawbacks. This fuel salt is expensive compared to most of the other alternatives, because

^7Li must be used to avoid excessive neutron absorption and tritium production. The high melting point would require a further increase in the minimum feedwater temperature, that contributes additional complications to the steam-system design. Two considerations must be added for the ABC plutonium-burner application. First, the additional absorptions in lithium if ^6Li were to be used and an IHX leak were to occur are not as critical in the ABC system because fissile-fuel breeding is no longer a concern. The additional neutron absorptions would, however, require a higher plutonium concentration and would lower the potential burnup (BSC, ??? am't we talking about the secondary coolant???)

The second option is to replace the steam power cycle by a helium cycle. Closed-cycle helium systems have been lately been studied for Modular Helium Reactor (MHR) applications and could be readily adapted for use in the ABC system. Inclusion of a secondary system between the helium and the fuel salt would increase the safety margin of the system, but the thermal-conversion efficiency would be decreased. Additional study of this cycle is needed to assess its viability.

A ternary fluoride eutectic, NaF-LiF-BeF_2 , was studied later in the MSBR study for use as a secondary coolant. This salt is cheaper than pure LiF-BeF_2 and has a much lower melting point. However, NaF-LiF-BeF_2 does not trap tritium. If some method of tritium trapping could be developed, the use of NaF-LiF-BeF_2 with a standard steam cycle would be advantageous. The NaF-LiF-BeF_2 salt is almost as compatible with the fuel salt as pure FLIBE. The sodium would increase parasitic neutron absorption, which portends problems in the event of an IHX leak, as well as the need for increased accelerator capacity; IHX in-leakage, however, would not affect the fuel salt (????). For plutonium applications, the effects of sodium addition on plutonium solubility would need to be determined. This salt could also be used in combination with a helium power-conversion cycle. The choice between LiF-BeF_2 and NaF-LiF-BeF_2 must be made based on the basis of the desirability of lower feedwater-temperature requirements *versus* the potential for adverse effects on the fuel salt in the event of mixing of the fuel and secondary coolant salts.

Liquid metals have never been considered for secondary coolants for use in combination with a molten-salt primary loop, but the use of liquid metals have been considered for use in combination with a LiF-BeF_2 secondary loop. The additional complexities associated with use of an additional coolant, however, may outweigh the advantages of a liquid metal such as sodium. One chemistry-related disadvantage of a liquid-metal coolant, for example sodium or lithium, is that if a leak between the liquid-metal loop and the LiF-BeF_2 loop occurs, the beryllium would be reduced to metallic form.

While helium also was not considered as a secondary coolant, this coolant was considered as a tertiary coolant for use in conjunction with a FLIBE secondary coolant. Helium provides one of the simplest method of tritium trapping. It is also chemically inert and fully compatible with the fuel salt (helium is to be used as the fuel-salt cover/stripping gas). If the tritium trapping can be developed for use in combination with a helium turbine system, (*i.e.*, pass helium stream over a tritium metal getter bed) this option may prove to be to be an attractive alternative.

a

4. Chemical Processing

As mentioned earlier, chemical processing is one of the least defined aspects of ABC. Without a knowledge of the required neutronic and chemical-transport parameters for the

ABC, alternative processing schemes that address valid reactor and processing problems cannot be proposed. The primary and alternate chemical-processing schemes that were chosen for the MSBR and MSRE were selected based on the criteria that were required efficient breeding of ^{233}U from ^{232}Th and to maintain the fuel-salt composition and fluoride chemical potential. Similar requirements are either not known or required for ABC. Regardless of the uncertainties of the proposed ABC system, an alternative separations technique that could be applied to chemical processing is centrifugation.

Centrifugation has been proposed to remove the low atomic weight (*i.e.*, light) fission product elements and the high-atomic-weight fission-products from the fissile material.⁴⁴ The principle of centrifugation is to create a gravitational field across a solution so that a concentration gradient according to light *versus* heavy atomic weight is established from the center of the centrifuge solution. In this application, fissile material is transported away from the center of the centrifuge, could be separated from the fission products, and then recycled to the core. The degree of separation between the fission products and fissile material could be enhanced by using a cascade of centrifuges. Fission products that are collected could be sent to an accelerator-driven waste burner. Centrifugation has been used extensively in separating mixtures that contain two phases, but application to single-phase separations is only recent.⁴⁴ The application of single-phase separations has focused on aqueous-solution, room-temperature systems and not on high-temperature molten-salt systems. The major disadvantage of the centrifuge method is that the additional chemistry and engineering problems that will be encountered with the high-temperature molten salt requires an extensive research and development program.

Another aspect of the chemical-processing subsystems of ABC that must be considered would occur if another fluid is chosen to carry the fissile material for the system; in this case the chemical processes would have to be tailored to the new fluid system. Processes that work well for molten-salt fluoride based systems probably would not work well for molten-salt chloride or molten carbonate systems.

5. Power-Conversion System

The reference power-conversion system for ABC was adopted from the MSBR design, which was in turn adopted from the Bull Run Steam Plant design²⁵. The supercritical-steam power-conversion system (Figs. 3 and 14) consists of: a steam generator (actually a superheater because the feedwater is supercritical steam); a high-pressure turbine; a reheat steam preheater; a full-flow steam reheater; an intermediate-pressure turbine; a low-pressure turbine; and a (complex) feedwater demineralizer/heater system. This power-conversion cycle maximizes the benefits of the high temperatures available from the molten salt and achieves a thermal-conversion of $\eta_{\text{TH}} = 0.44$. The use of the supercritical-steam cycle, however, introduces design difficulties. The required wall thicknesses of pipes and vessels required to contain this 25-MPa steam limit the diameter of piping and steam-generator components and, therefore, limit design options. Concerns of higher pressures in the steam generator also introduces concerns of rupture and pressurization of the secondary coolant system.

As part of the MSBR program, alternate steam cycles were considered. None was pursued, however, because of the limited resources and the availability of detailed design information on the supercritical-steam cycle from the Bull Run design. Additional analysis may show that the reduction in cycle efficiency that would accompany a change to lower-

pressure steam is more than offset by the reduced complexity of the steam system. This analysis must also include an examination of alternative secondary coolants. A combination of the ternary eutectic as a secondary fluid and a lower-pressure steam power conversion cycle is deserved of further analysis. Although some disagreement exists (??), it may be possible to eliminate the complex feedwater heating system because of the lower melting point of the tertiary eutectic.

Another option for the power conversion system is to use helium or nitrogen in a closed cycle. Use of either gas coolant would require larger heat exchangers, but those for the nitrogen cycle would be even larger. Some preliminary calculations show that for the assumed conditions, nitrogen may yield a slightly higher efficiency. This gain, however, would have to be balanced against the additional capital requirements of the larger equipment and containment. In this scenario, the entire power conversion system would be placed inside containment. Only the final heat sink water and the power lines would penetrate the containment. Additional analyses are required to determine the cycle efficiencies, costs, tritium removal capability, safety, *etc.* of the helium (or nitrogen) turbine power cycle.

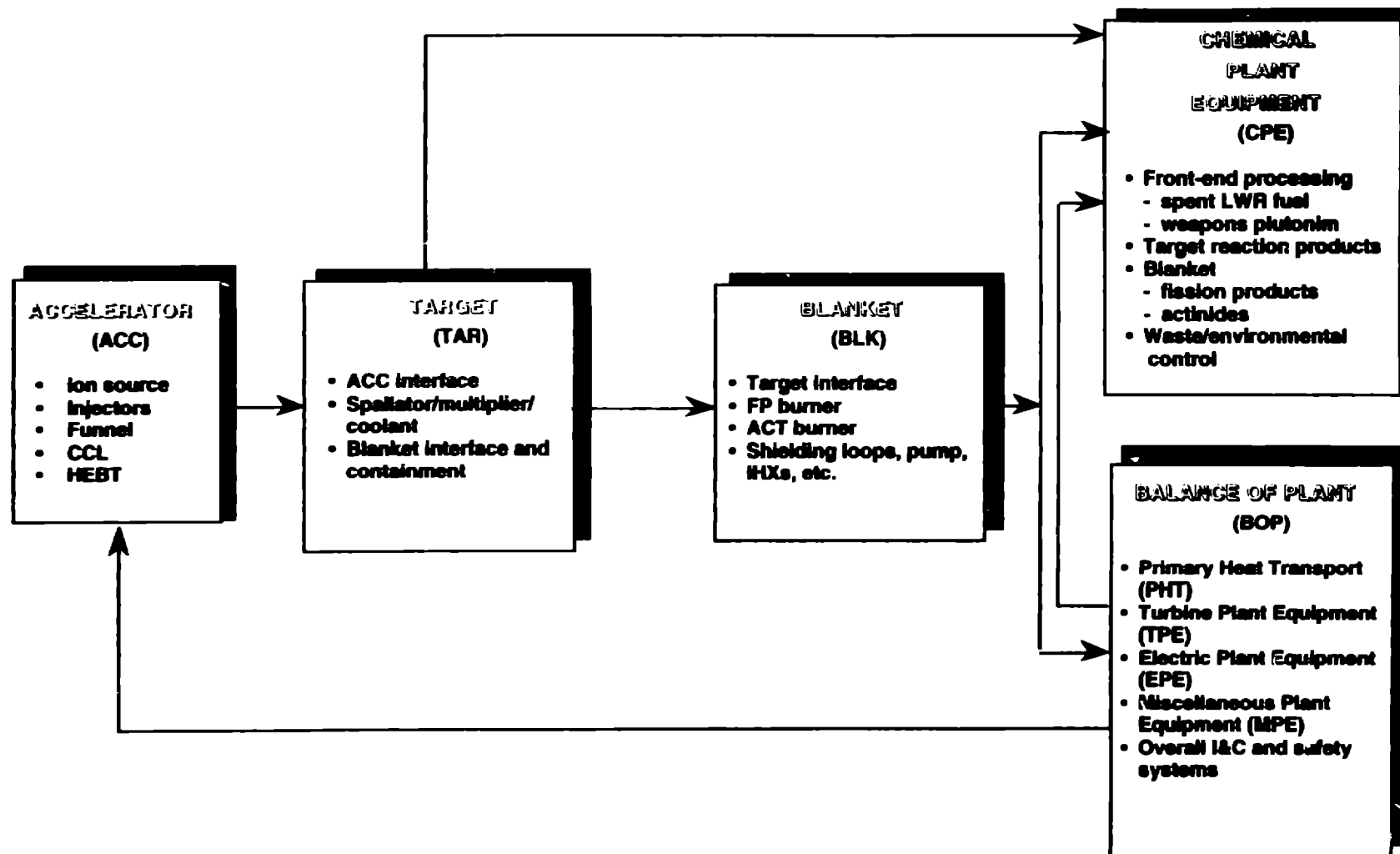

Figure 1. Top-level ATW/ABC systems diagram showing main subsystems and main mass/power flows.

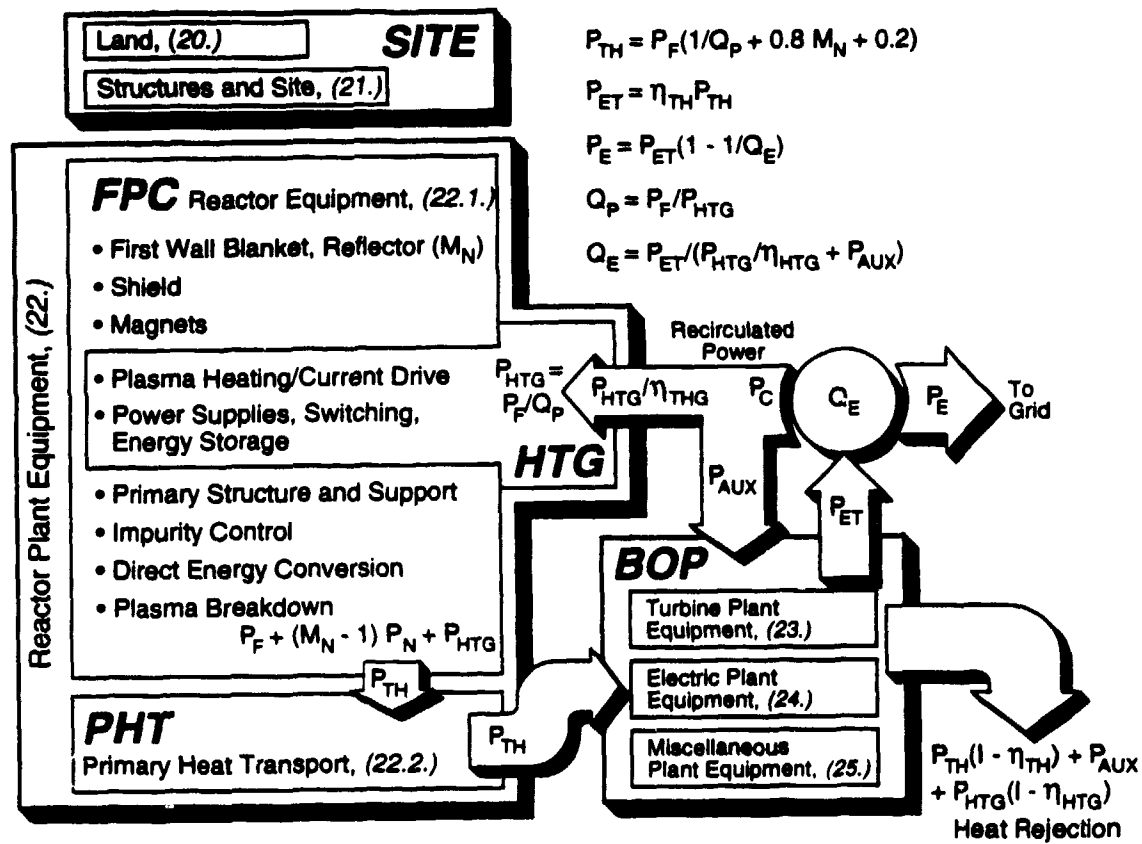

Figure 2. Re-expression of subsystems flows depicted in Fig. 1 showing main power flows and arranged according to EEDB^{12,13} Program of Cost Accounts

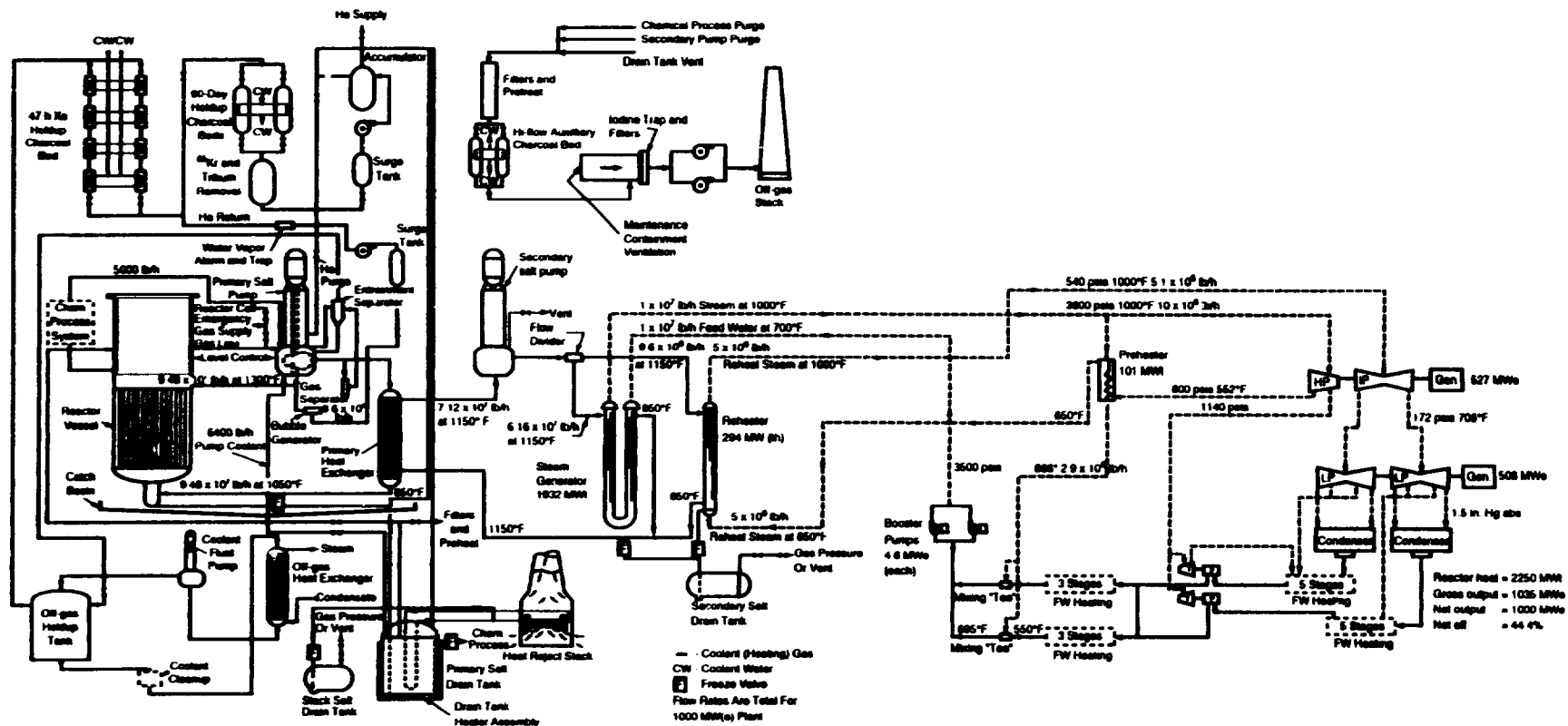

Figure 3. Composite power and mass flow diagram for the conceptual Molten-Salt Breeder Reactor (MSBR)¹⁰ and adapted to the basecase ABC plant layout.

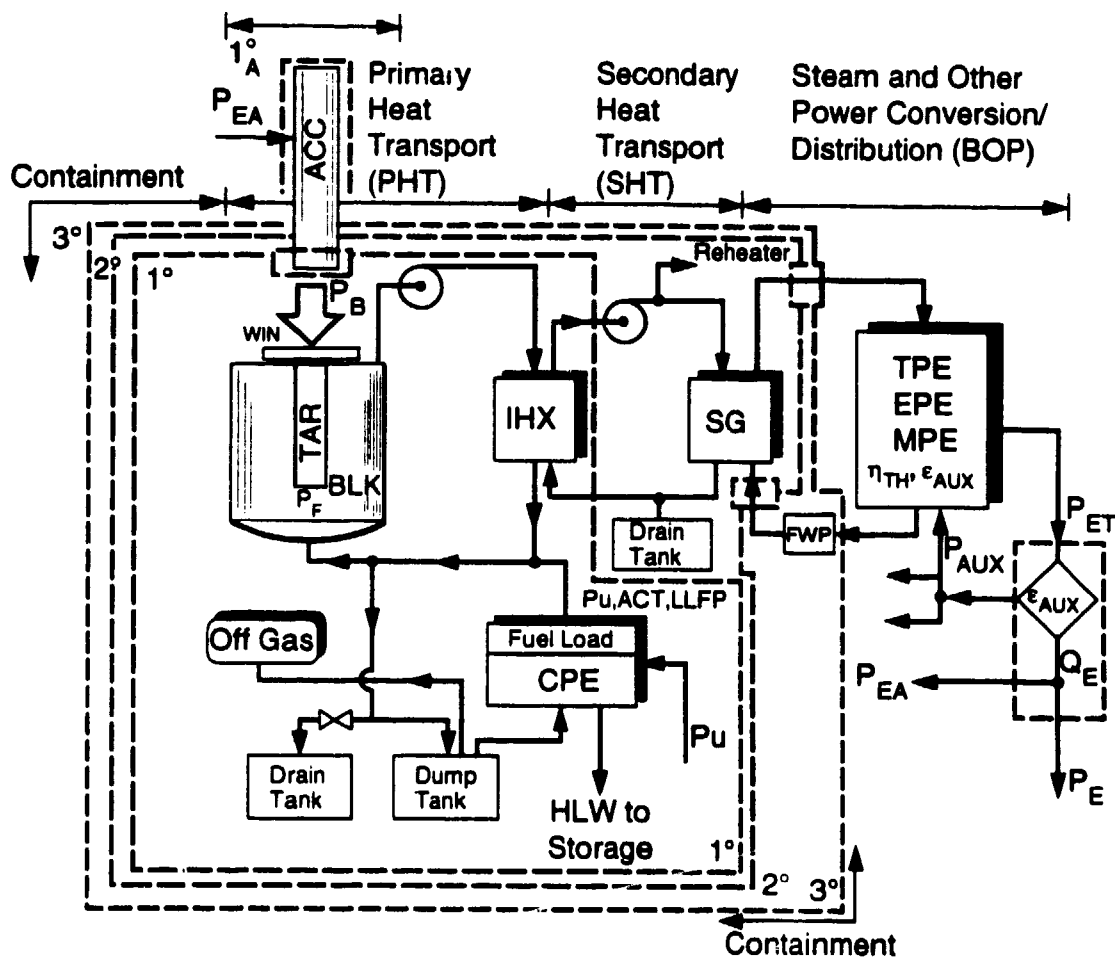

Figure 4. Essential elements of the ABC system for "deep-burn" weapons-plutonium disposition and net power production, showing main power and mass flows as well as three-level containment philosophy

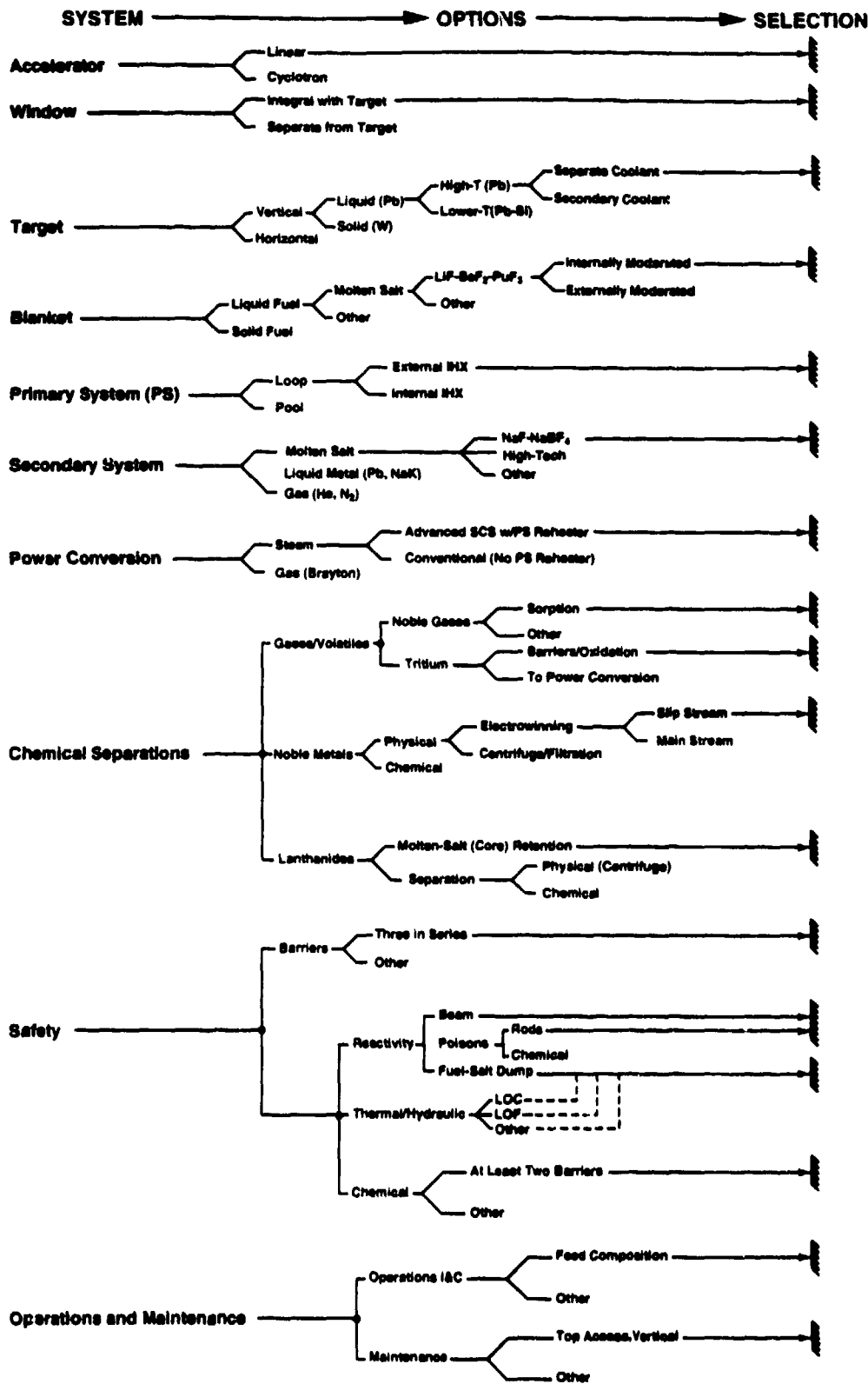

Figure 5. "Top-level" options diagram for ABC, illustrating process used to focus onto the base case used to generate preliminary ABC plant layout.

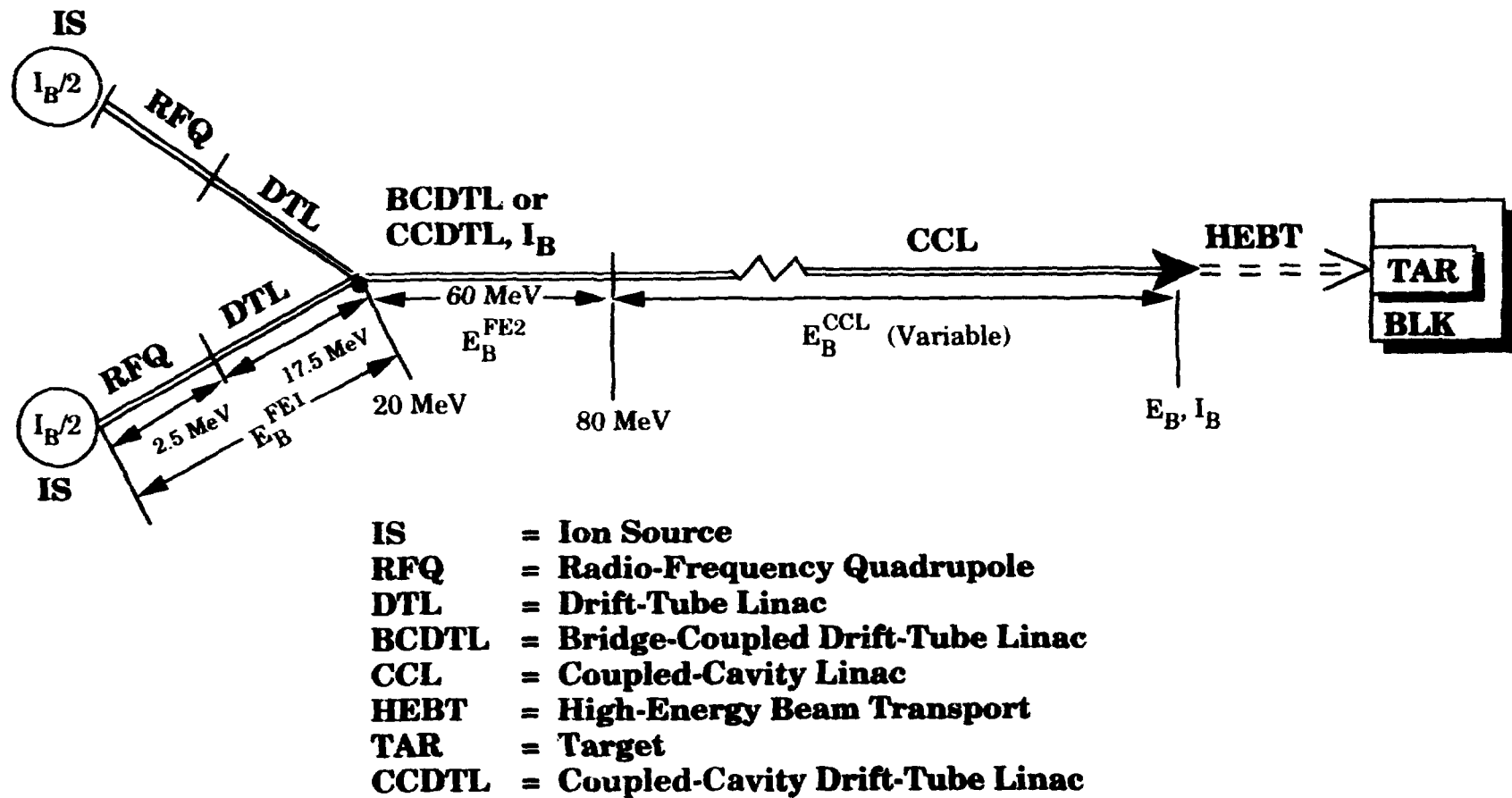

Figure 6A. Linear accelerators proposed to drive ABC "top-level" systems diagram of ABC accelerator, showing main components.

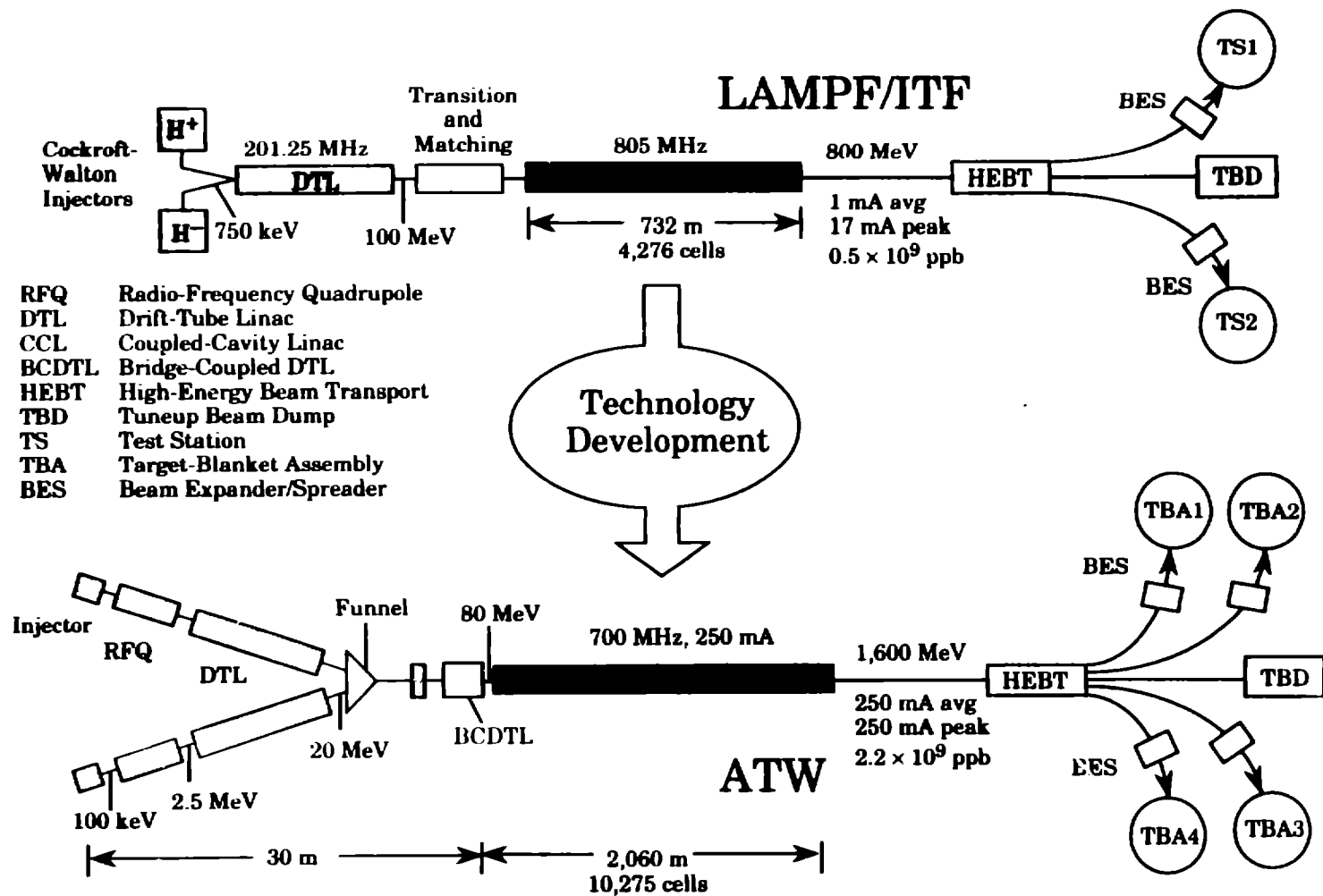

Figure 6B. Linear accelerators proposed to drive ABC: Graphical illustration of technology development required to proceed from present LAMPF,^{16,17} through an Integrated Test Facility,¹⁸ and to a 1.6-GeV high-current accelerator.

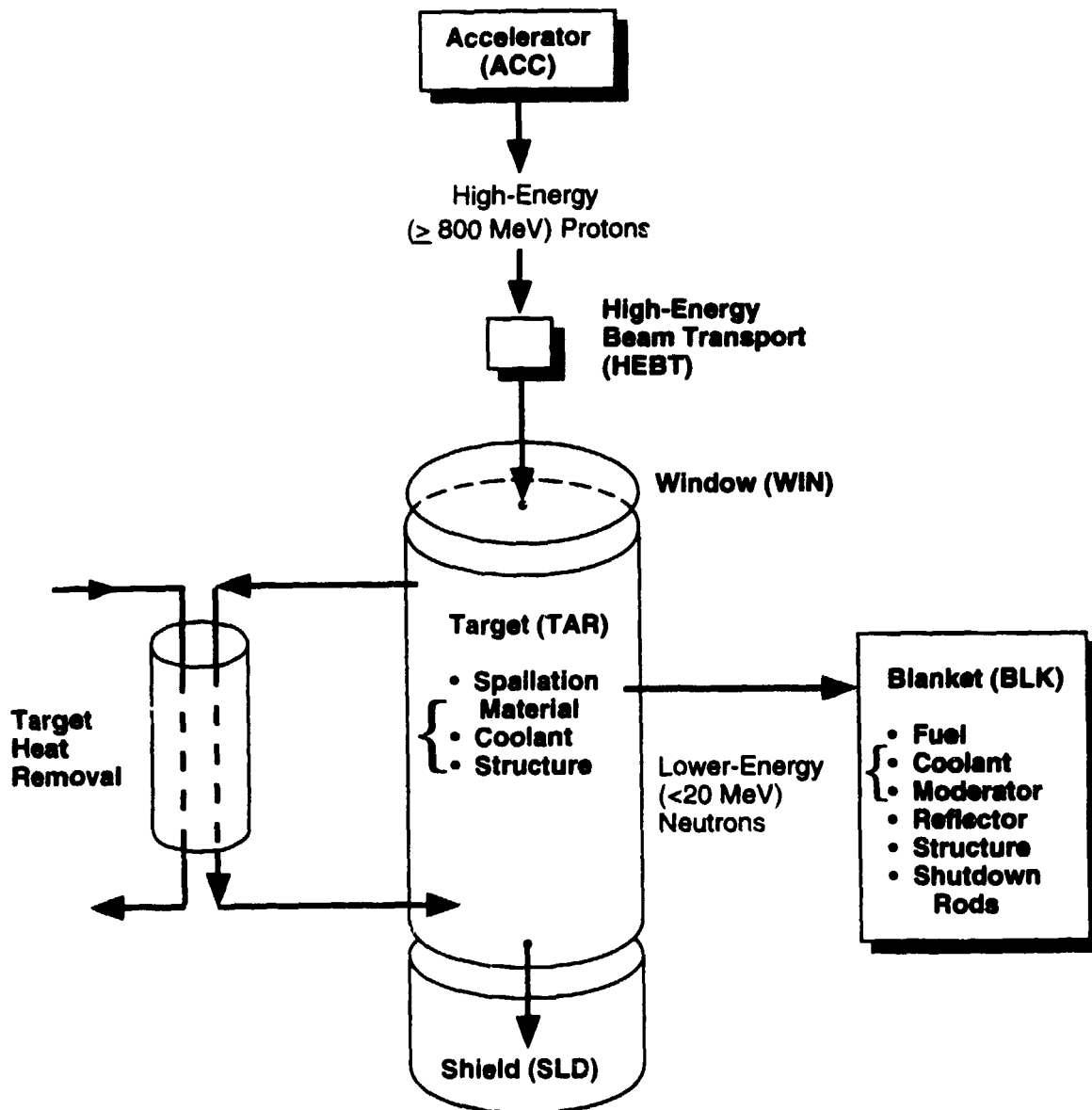

Figure 7. Schematic diagram illustrating target functional performance and connectivity with key ABC subsystems.

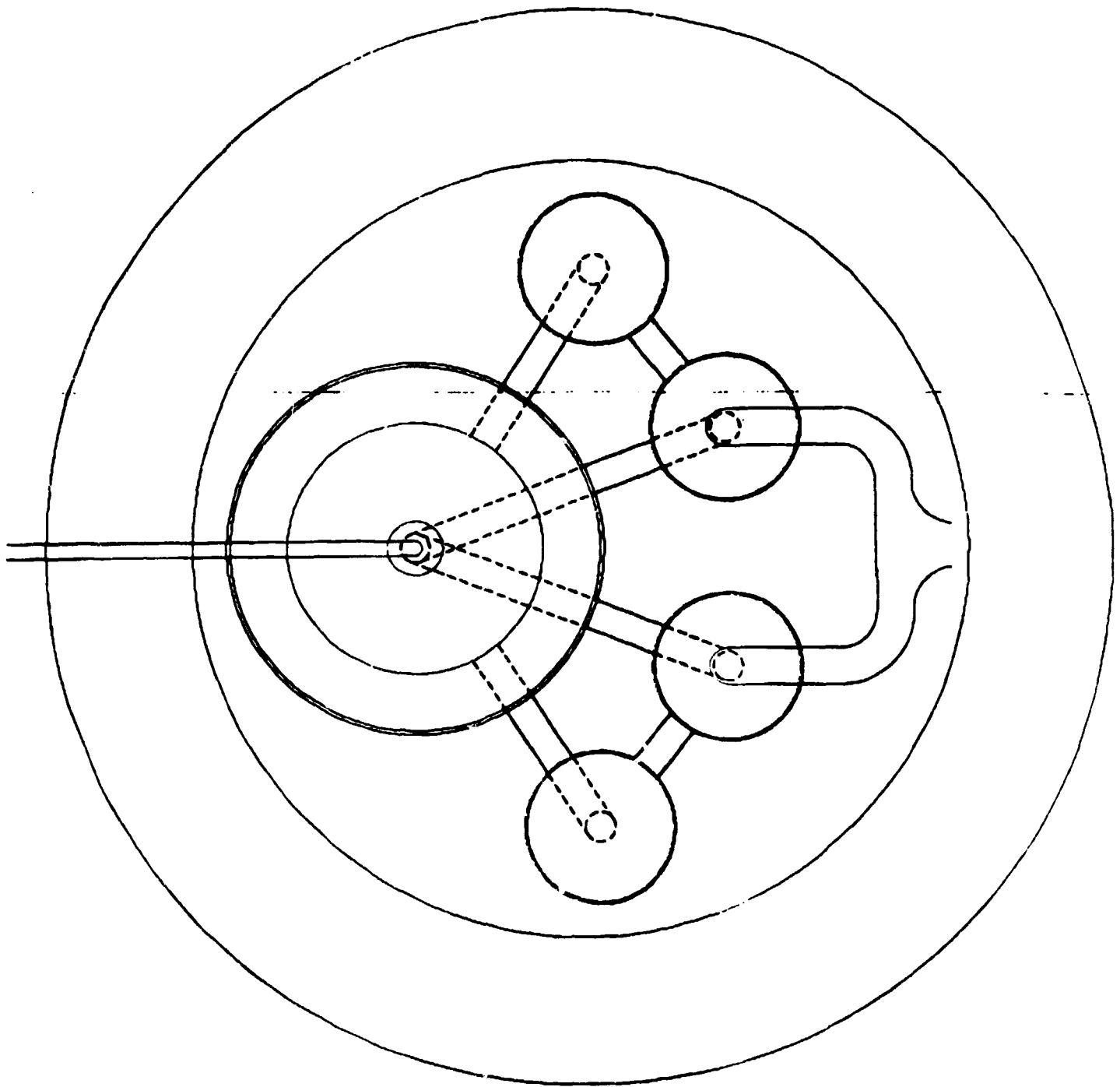

Figure 8. Plan view of Primary System: Core (Target/Blanket/Moderator/ Reflector, Reactor Vessel); Fuel-Salt Pumps; Intermediate Heat Exchanger; and interconnecting piping.

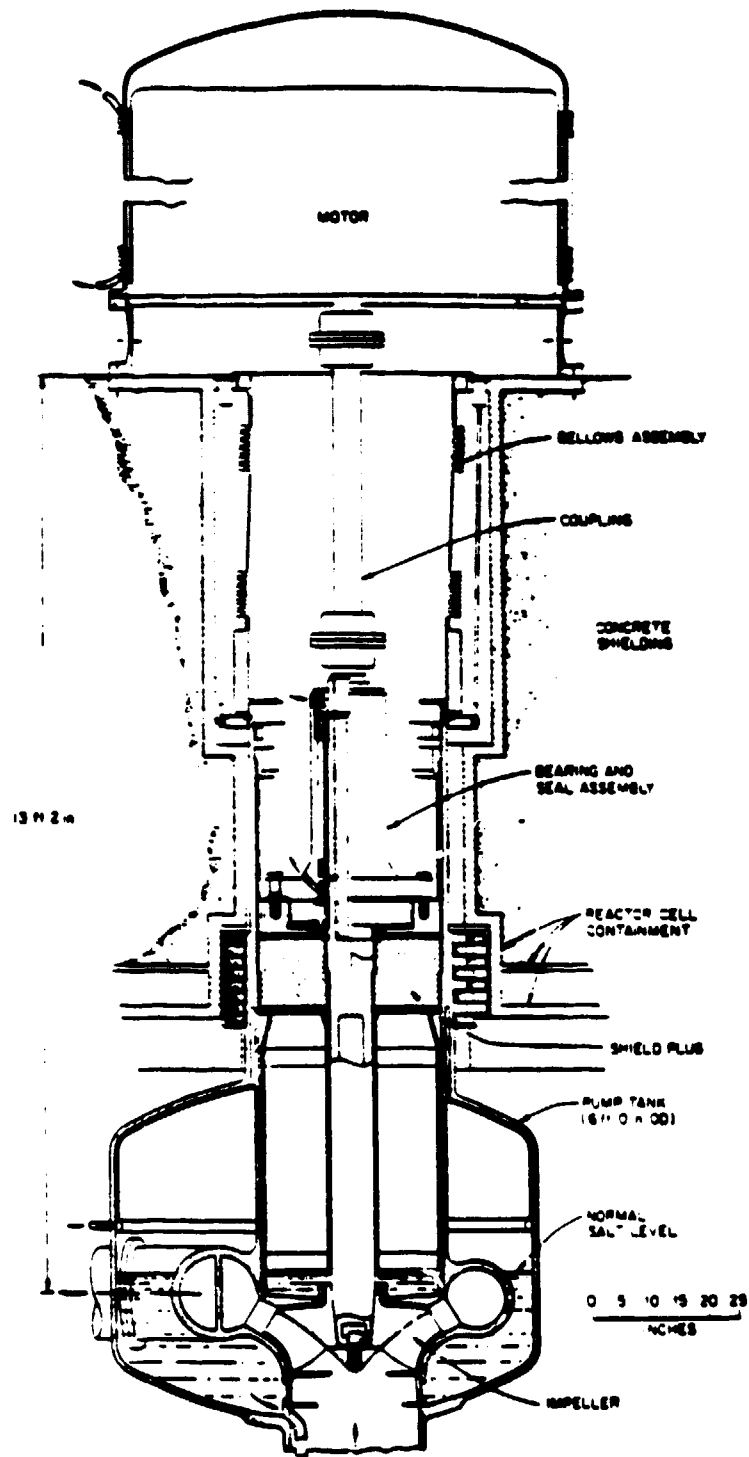

Figure 9. Detailed view of Fuel-Salt Pump; Secondary Coolant-Salt Pump is similar.¹⁰

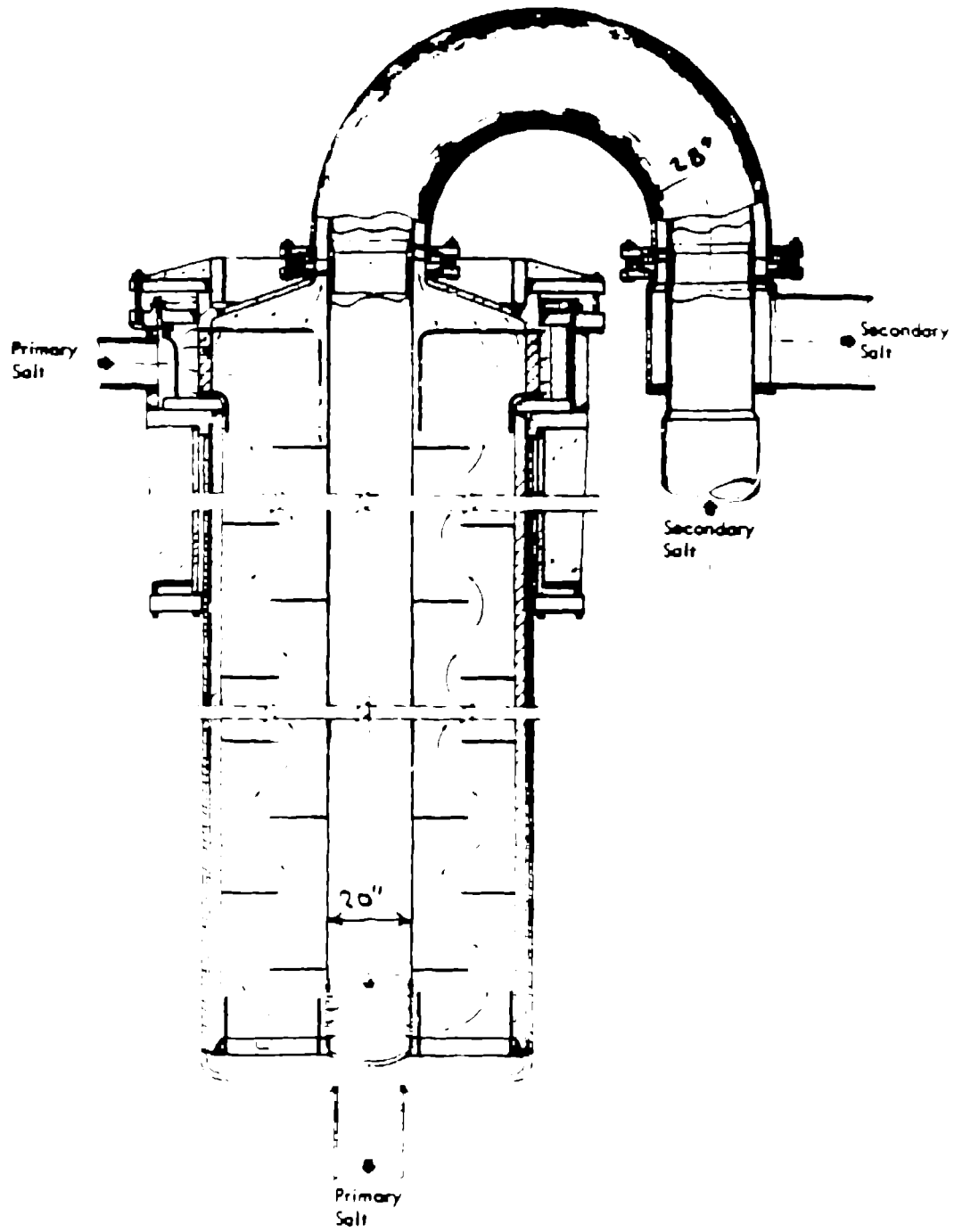

Figure 10. Detailed view of Intermediate Heat Exchanger.¹⁰

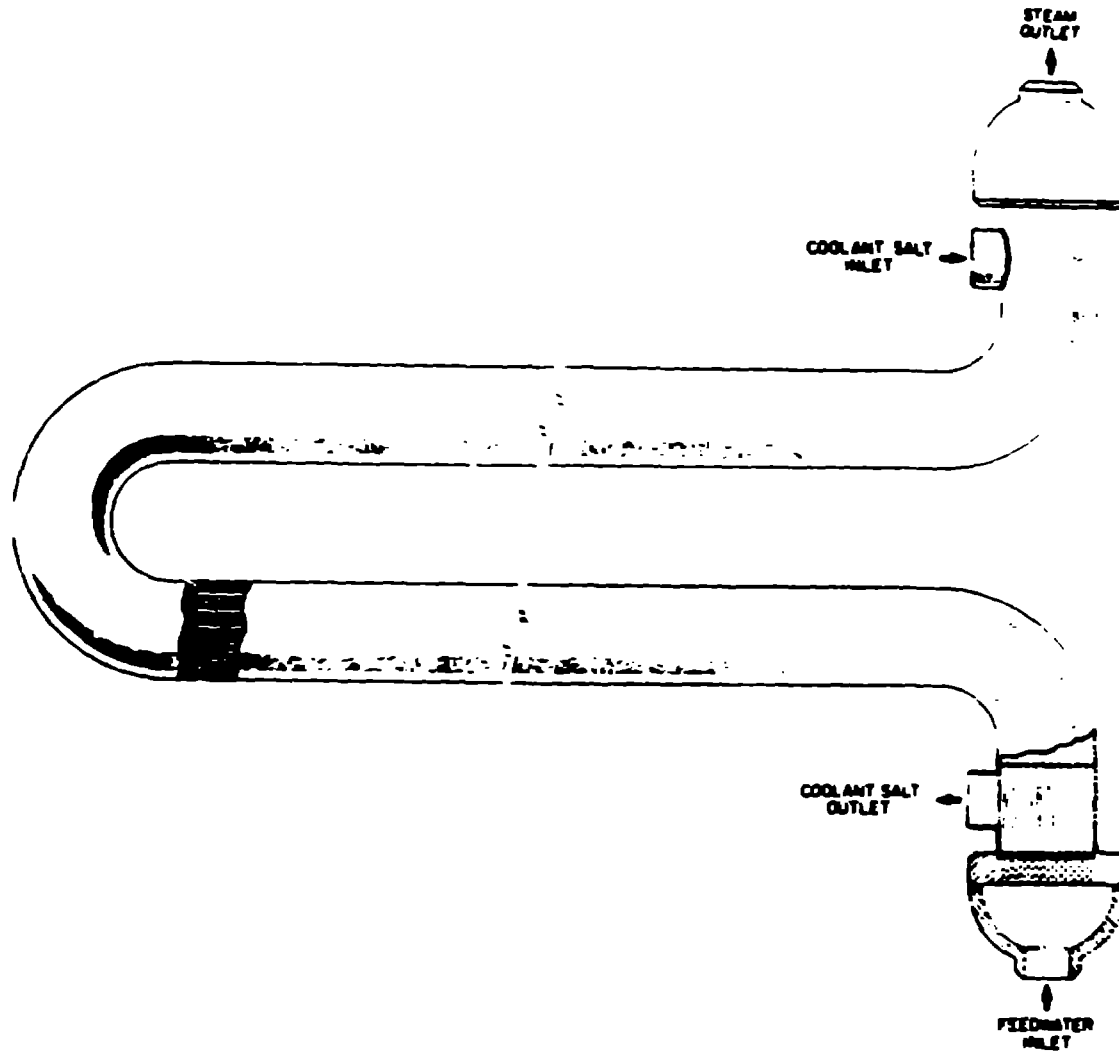

Figure 11A. Detailed view of Steam Generator: From MSBR conceptual design.¹⁰

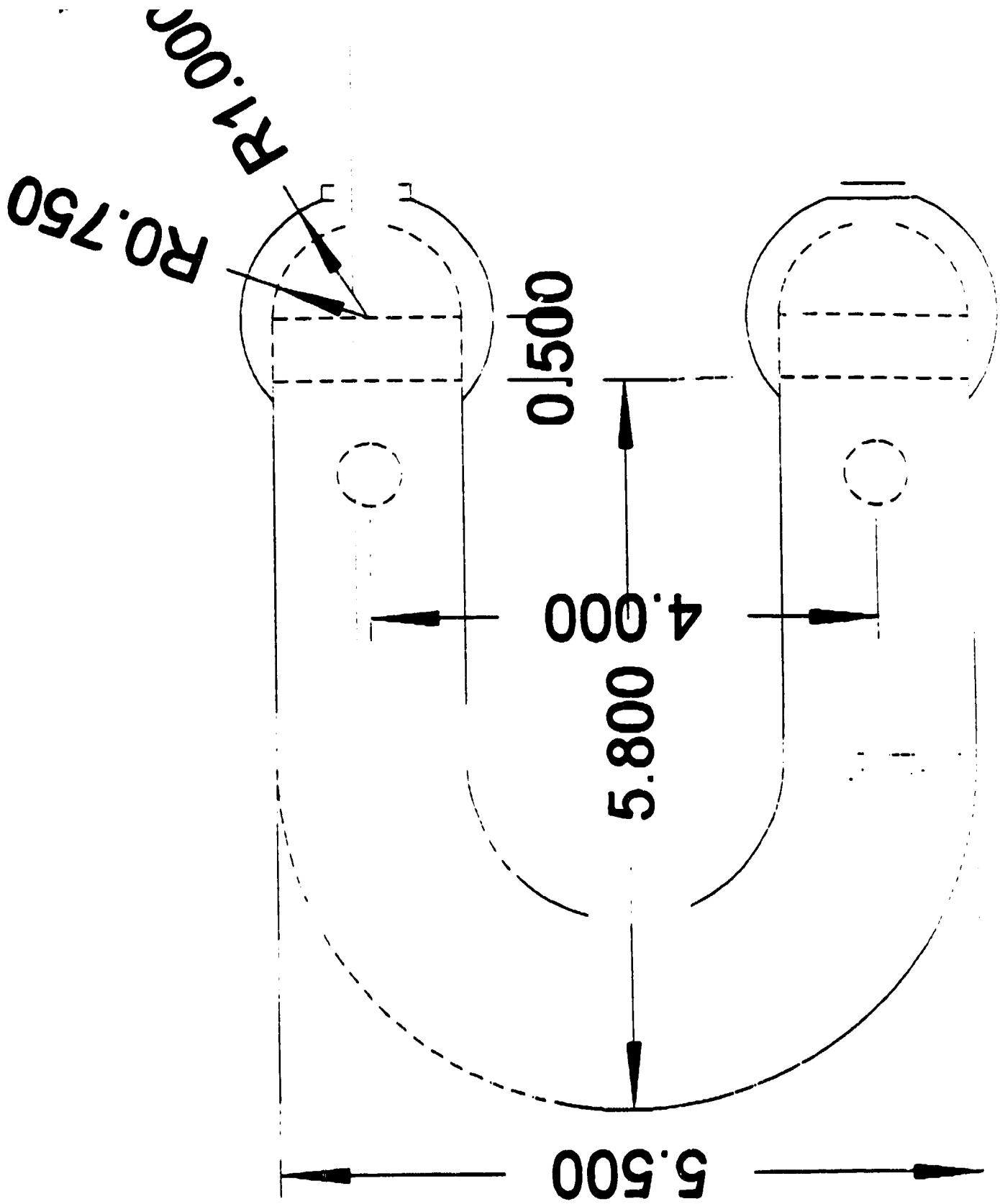

Figure 11B. Detailed view of Steam Generator: Scaled from MSBR¹⁰ to meet ABC requirement.

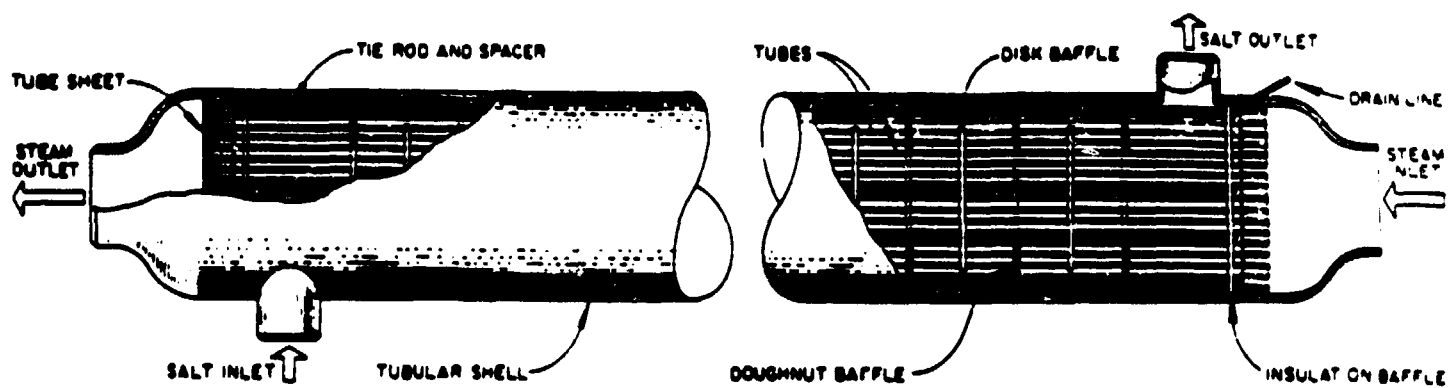

Figure 12.A Detailed view of Steam Reheater for ABC; scaled from MSBR conceptual design¹⁰

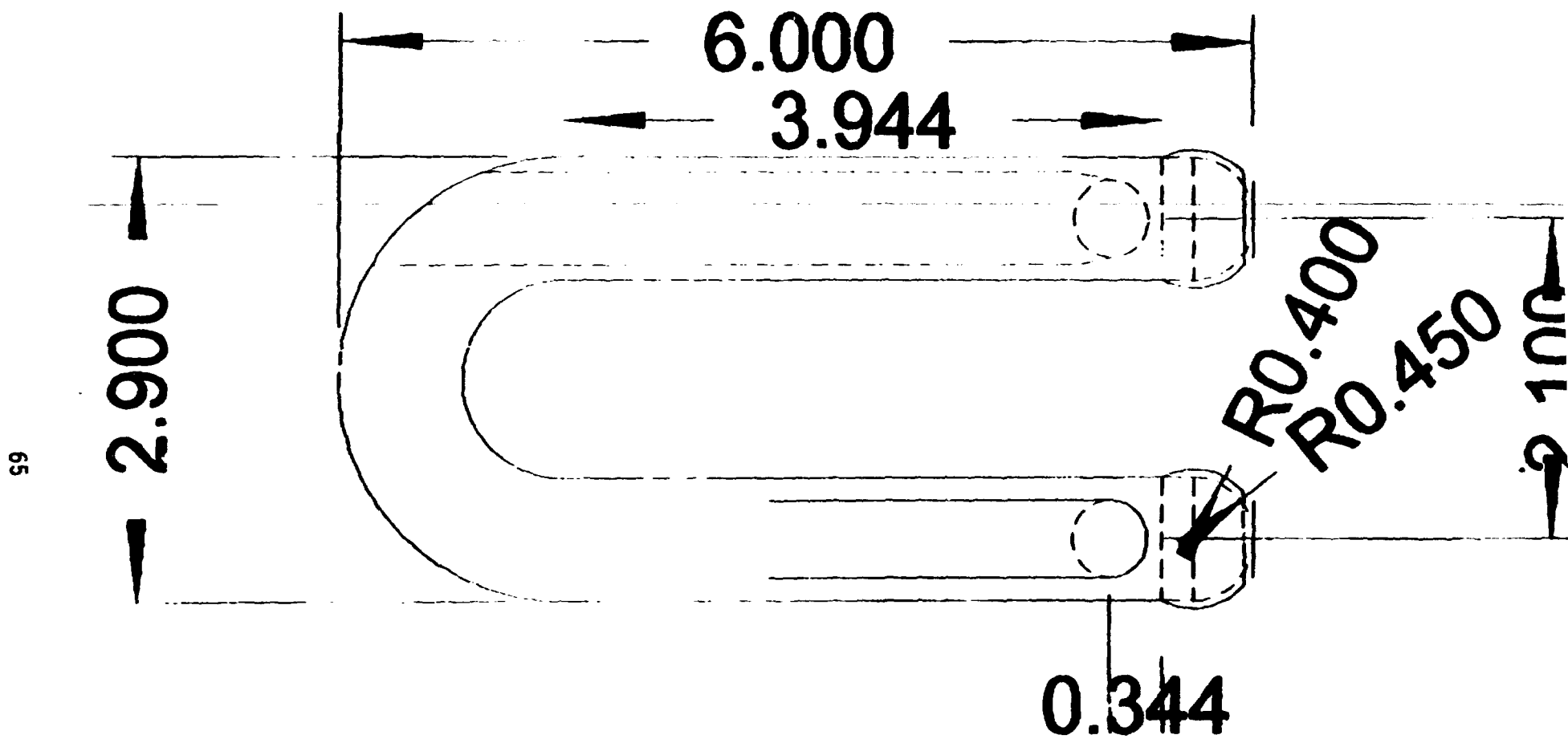

Figure 12B. Detailed view of Steam Reheater for ABC; scaled from MSBR¹⁰ to meet ABC Requirements.

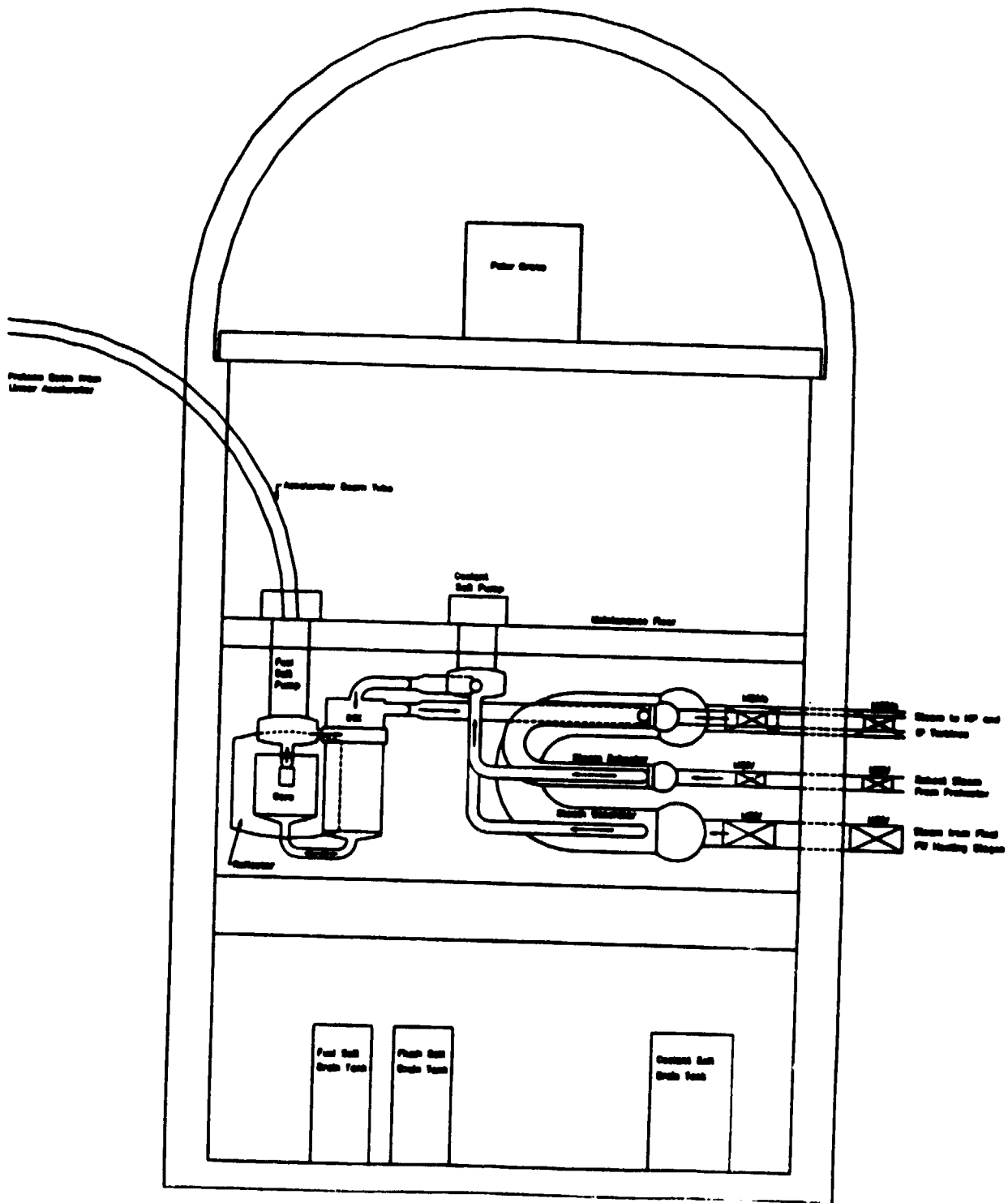

Figure 13A. Plan and elevation views of ABC plant layout: Elevation view.

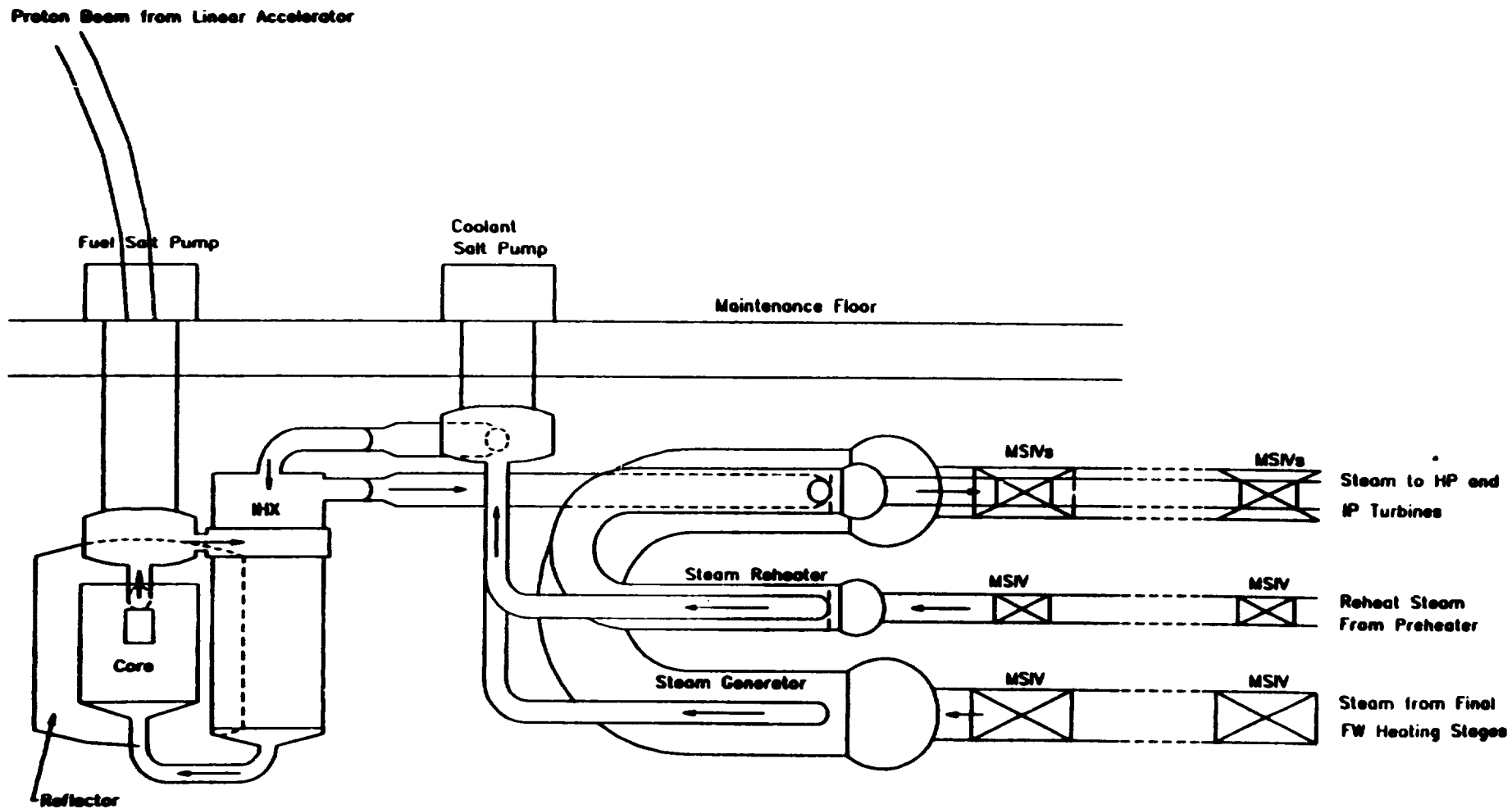

Figure 13B. Plan and elevation views of ABC plant layout: Elevation view (detailed).

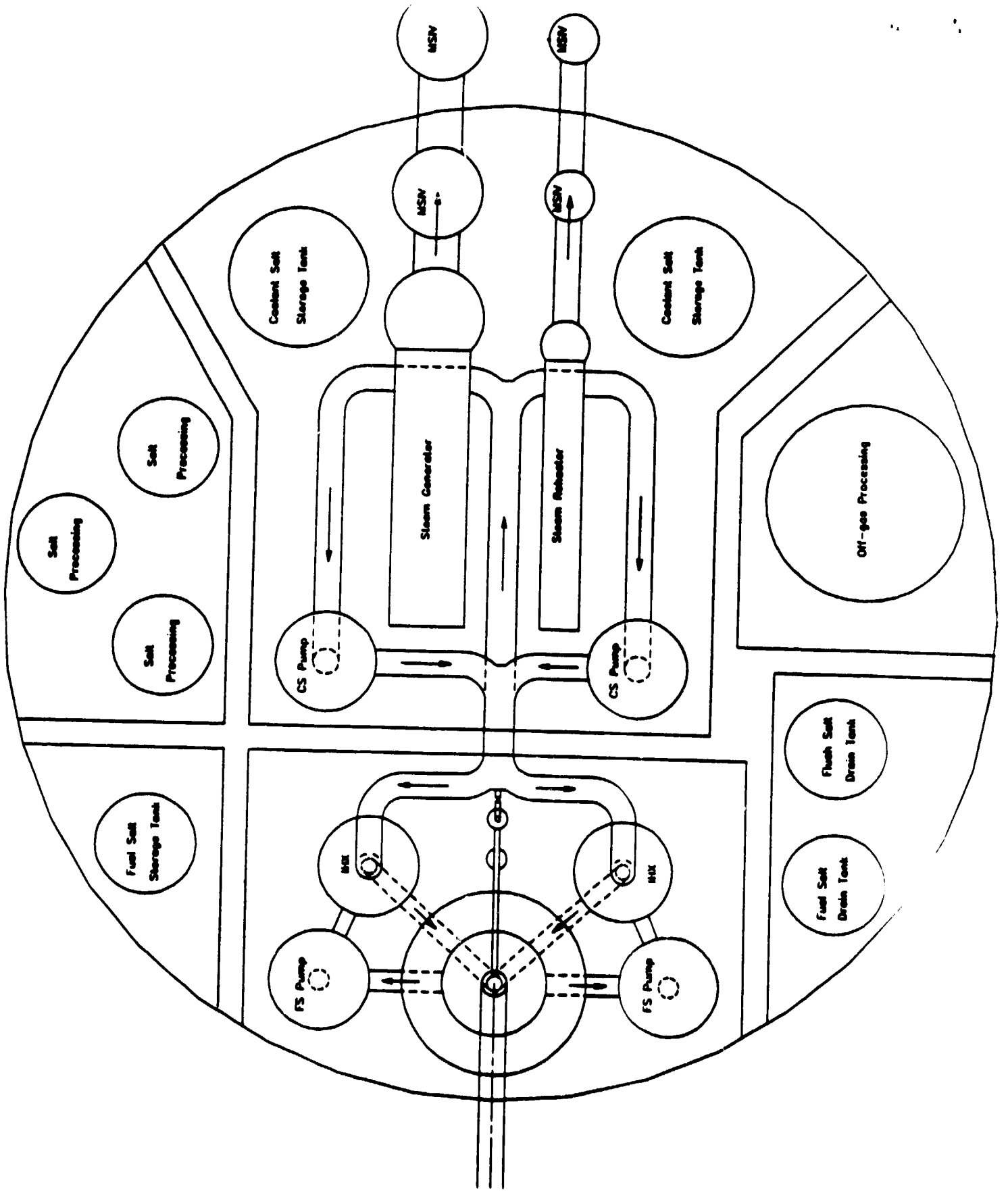

Figure 13C. Plan and elevation views of ABC plant layout: Plan view.

REFERENCES

1. R. J. Jensen, T. J. Trapp, E. D. Arthur, J. W. Davidson, and R. K. Linford, "Accelerator-Based Conversion (ABC) of Reactor and Weapons Plutonium," Proc. Intern. Conf. on Future Nuclear Systems: Emerging Fuel Cycles and Waste Disposal Options, 2, 833 (September 12-17, 1993).
2. C. D. Bowman, Overview of the Los Alamos Accelerator-Driven Transmutation Technologies," Proc. 1994 Intern. Conf. on Accelerator-Driven Transmutation Technologies and Applications Program, Las Vegas NV (July 25-29, 1994).
3. E. D. Arthur, J. J. Buksa, J. W. Davidson, and D. ? Poston, Discriminators for the Accelerator-Based Conversion (ABC) Concept Using a Subcritical, Molten-Salt System," Los Alamos National Laboratory document LA-UR-94-3700 (October 1994).
4. "Management and Disposition of Excess Weapons Plutonium," National Academy of Sciences report ????, National Academy of Sciences Press, Washington DC (1994).
5. "Plutonium Working Group Report on Environmental, Safety, and Health Vulnerabilities Associated with the Department's Plutonium Storage," United States Department of Energy report DOE/EH-0415 (October 1994).
6. C. G. Beard and J. J. Park, personal communication, Los Alamos National Laboratory (1994).
7. W. C. Sailor and J. W. Davidson, "MEDAL: A Time-Dependent Computational Methodology for Very High Burnup Systems," private communication, Los Alamos National Laboratory (February 10, 1995).
8. M. A. Williamson, "The Chemistry of Accelerator-Driven Molten-Salt Nuclear Reactors," Los Alamos National Laboratory document LA-UR-95-xxxx (in preparation, 1995).
9. E. D. Arthur, "ABC R&D Plan," Los Alamos National Laboratory document LA-UR-xxxx (in preparation, 1995).
10. R. C. Robertson (ed.), "Conceptual Design Study of a Single-Fluid Molten-Salt Breeder Reactor," Oak Ridge National Laboratory report ORNL-4541 (June 1971).
11. A. M. Weinberg, "Molten-Salt Reactors," and accompanying papers in special issue of Nucl. Techno., 8(2) (1970).
12. "Nuclear Energy Cost Data Base - A Reference Data Base for Nuclear and Coal-Fired Power Plant Generation Cost Analysis," United States Department of Energy report DPE/NE-0095 (September 1984).

13. J. G. Delene and C. R. Hudson II, "Cost Estimate Guidelines for Advanced Nuclear Power Technologies," Oak Ridge National Laboratory report ORNL/TM-10071/R3 (March 1993).
14. R. A. Krakowski, "ATW Economics," Nucl. Technol. (to be published, 1995) [also Los Alamos National Laboratory document LA-UR-93-2231(REV.) (August 22, 1994)].
15. R. A. Krakowski, "Cost-Based Optimization of Power Density and (Target- Blanket) Modularity for ADEP: Accelerator-Driven Energy Production," Submitted to Global 95: Intern. Conf. on Evaluation of Emerging Nuclear Fuel Cycle Systems, Versailles, France (September 11-14, 1995) [also, Los Alamos National Laboratory document LA-UR-94-3564 (October 20, 1994) and LA-UR-94-3946 (November 18, 1994)].
16. J. B. McClelland (chm.), "Technical Assessment of Possible Applications of the LAMPF Accelerator Complex Beyond LANSCE II," LANSCE II Advisory Committee Working Group report, Los Alamos National Laboratory (October 5, 1993)
17. H. A. Thiessen (chm.), "Alpha: A Possible LAMPF-Based Experimental Configuration for ADTT and Next-Generation LANSCE Concepts," Los Alamos National Laboratory document LA-UR-94-1088 (June 13, 1994).
18. C. A. Beard, J. J. Buksa, J. W. Davidson, M. Houts, R. A. Krakowski, G. F. Niederauer, and L. L. Wang, "An Integrated Test Facility (ITF) for Applications of Accelerator-Driven Transmutation: Preliminary Definition Study and Assessment," Los Alamos National Laboratory document LA-UR-93-4350 (December 13, 1993).
19. C. D. Bowman, *et al.*, "Nuclear Energy Generation and Waste Transmutation Using Accelerator-Driven Intense Thermal Neutron Source," Nucl. Instr., A230, 336 (1992).
20. E. D. Arthur, *et al.* "The Los Alamos Accelerator Transmutation of Nuclear Waste (ATW) Concept", Los Alamos National Laboratory document LA-UR-92-2020 (April 15, 1992).
21. C. Bowman, private communication, Los Alamos National Laboratory (1994).
22. B. Blind, "A Beam-Delivery System for the ATWE," private communication, Los Alamos National Laboratory (1994).
23. LMR liquid-metal transfer. [CAB]
24. Oak Ridge National Laboratory report ORNL/TM-5759. [BSC]
25. "Bull Run Steam Plant Design", TVA Technical Report #38. [more??, BSC]

26. R. A. Krakowski, "APT Cost Scaling: Preliminary Indications form a Parametric Costing Model (PCM)," Los Alamos National Laboratory document LA-UR-95-631 (February 3, 1995).
27. Proc. DOE-Sponsored Workshop on APT Technology Demonstration/Risk Reduction, Los Alamos National Laboratory, Los Alamos, NM (January 31 - February 2, 1995).
28. APT Project, "³He Target/Blanket Topical Report," Los Alamos National Laboratory report LA-12670-MS, Vol. I (September 30, 1993).
29. J. S. Fraser and G. A. Bartholomew, Neutron Sources for Basic Physics and Applications: Chapter 10, Pergamon Press, New York, New York (1983).
30. J. M. Carpenter, "Pulsed Spallation Neutron Sources for Slow Neutron Scattering," Nuclear Instruments and Methods, 145, 91-113 (1977).
31. J. S. Fraser, et al., "Neutron Production in Thick Targets Bombarded by High Energy Protons," Phys. Canada, 21, 17-18 (1965).
32. W. R. Grimes, F. F. Blankenship, G. W. Keilholtz, H. F. Poppendiek, and M. T. Robinson, "Chemical Aspect of Molten Fluoride Reactors," Prog. Nucl. Energy; Series IV, 2, Pergamon Press, London (1960).
33. J. V. Cathcart and W. D. Manly, "The Mass Transfer Properties of Various Metals and Alloys in Liquid Lead", Corrosion , 12, 43-47, (1956).
34. J. J. Buksa, *et al.*, "Conceptual Design of a Thorium Target for Molten- Salt Transmutation Systems," Proceedings of the Intern. Conf. on Accelerator-Driven Transmutation Technologies and Applications, Las Vegas, NV (July 25-29, 1994).
35. G. M. Tolson and A. Taboada, "A Study of Lead and Lead-Salt Corrosion in Thermal-Convection Loops", Oak Ridge National Laboratory report ORNL-TM-1437 (1966).
36. R. N. Lyon (ed.), "Liquid Metals Handbook", Atomic Energy Commission, Department of the Navy, Washington, D. C., NAVEXOS P-733 (Rev.) (June 1952).
37. J. F. Breismeister, "MCNP-A General Monte Carlo N-Particle Transport Code," Los Alamos National Laboratory report LA-12625-M (1993).
38. A. G. Croff, "ORIGEN2: A Versatile Computer Code for Calculating the Nuclide Compositions and Characteristics of Nuclear Materials," Nucl. Technol. 62, 335 (1983).
39. B. P. Kochurov, "An Advanced Method of Heterogeneous Reactor Theory," Japanese Atomic Energy Research Institute report JAERI-Review 94-002 (1994??).

40. D. ?? Garber (Ed.), "ENDF/B-V," Brookhaven National Laboratory report BNL-17541 (ENDF-201) National Nuclear Data Center (October 1975).[WCS]
41. R. J. Howerton, et. al., "The LLL Evaluated Nuclear Data Library (ENDL): Evaluations Techniques, Reaction Index and Descriptions of Individual Reactions," Lawrence Livermore National Laboratory report UCRL-50400, Vol. 15, Part A (September 1975).
42. R. W. Hamming, Numerical Methods for Scientists and Engineers, 2nd Ed., McGraw Hill Book Co. New York (1973).
43. R. S. Babcock, D. E. Wessol, C. A. Wemple, and S. C. Mason, "The MOCUP Interface: A Coupled Monte Carlo/ Depletion System., Proc. 1994 T Top. Mtg on Advances in Reactor Physics, Knoxville, TN (April 11-15, 1994). American
44. N. Li and F Venneri, personal communication, Los Alamos National Laboratory (1994).
45. G. Lawrence, private communication, Los Alamos National Laboratory (1993).
46. "The Development Status of Molten-Salt Breeder Reactors," Oak Ridge National Laboratory report ORNL-4812 (August 1972).
47. L. E. McNeese, "Program Plan for Development of the Molten-Salt Reactor Program," Oak Ridge National Laboratory report ORNL 5018 (December 1974).
48. E. S. Bettis and W. K. Erger, "Aircraft Reactor Experiment." **Fluid Fuel Reactors**, Addison-Wesley, Reading MI, (1958).
49. APT Accelerator Design [RAK].
50. G. P. Lawrence, "High-Power Linac for Transmuting the Long-lived Products in Nuclear Waste Conf. Record 1991 IEEE Particle Accelerator Conference, 4, 2598 (May 6-9, 1991).
51. Mark's Standard Handbook for Mechanical Engineers [BSC].
52. J. H. DeVan, J. R. DiStefane, W. P. Eatherly, J. R. Keiser, and R. L. Klueh, "Materials Considerations for Molten Salt Accelerator-Based Plutonium Conversion Systems," Oak Ridge National Laboratory report ORNL/TM-???? (October 1994) [BSC].

NOMENCLATURE [mks units only, with anything else enclosed by parentheses in text]

a(m)	Beam-tube radius
ABC	Accelerator-Based Conversion
ACC	ACCelerator
ACS	Absorption Cross Section
ACT	ACTinide
ADEP	Accelerator-Driven Energy Production
ADTT	Accelerator-Driven Tritium Technologies
ATW	Accelerator Transmutation of (nuclear) Waste
ATWS	Anticipated Transient Without SCRAM
ATWE	ATW Experiment
AUX	AUXiliary
B(T)	Magnetic field
BLK	BLanKet (moderator, fuel salt, reflector, structure)
BCDTL	Bridge-Coupled DTL
BES	Beam Expander/Spreader
BM	Bending Magnet
BOL	Beginning Of Life
BOP	Balanced of Plant
BTIV	Beam-Tube Isolation Valve
C_j(M\$)	Cost of j^{th} component
c(m/s)	Speed of light, 3×10^8
c_j(\$/x)	Unit cost of i^{th} component, x = kg, W, etc.
CCDTL	Coupled-Cavity DTL
CCL	Coupled-Cavity Linac
COR	CORe [target, blanket (moderator, reflector, structure, salt)]
CPE	Chemical Plant Equipment
CR	Control Rod
CSP	Coolant-Salt Pump
CS	Confinement Systems
CSS	Core Support Systems
DTL	Drift-Tube Linac
e(J/eV)	Electronic charge, 1.6021×10^{-18}
E_B(MeV/p)	Proton beam energy
E_n(GeV)	Proton rest-mass energy
E_B^0(Mev/p)	Target yield fitting parameter
E_F(Mev/f)	Fission energy release
E_n(MeV/n)	"Wall-plug" energy to create a neutron
ECRH	Electron Cyclotron Resonance Heating
EEDB	Energy Economic Data Base
$(E_n)_{\infty}$(MeV/n)	Normalizing parameter, $y/(\eta_{DC}\eta_{RF}\eta_{WG})$
EOL	End Of Life
EPE	Electric Plant Equipment
f_{BU}	Plutonium burnup fraction
f_D	Proton-beam duty factor

f_{FS}	Volume fraction of fuel salt
FE	Front End (accelerator)
FF	Fluid Fuel
FP	Fission Products
FSP	Fuel-Salt Pump
FWP	FeedWater Pump
$G(\text{MV/m})$	"Real-estate" acceleration gradient
$G_j(\text{m}^3/\text{s})$	Volumetric flow rate
$H_j(\text{m})$	Height of j^{th} system
HEBT	High-Energy Beam Transport
HEU	Highly Enriched Uranium
HLW	High Level Waste
$I_B(\text{A})$	Proton beam current
$I^*(\text{A})$	Cavity \rightarrow beam conversion efficiency factor, $f_D G/R_s/\cos\phi$
IHX	Intermediate Heat eXchanger
ITF	Integrated Test Facility ¹⁸
$Q_{\text{EXP}}(\text{m})$	beam expansion distance
$j(\text{MA}/\text{m}^2)$	Conductor current density
k_{eff}	Blanket neutron multiplication
$L_j(\text{m})$	Length/height of j^{th} system
LAMPF	Los Alamos Meson Physics Facility
Linac	Linear accelerator
LLFP	Long-Lived Fission Product
LLW	Low-Level Waste
LMFR	Liquid-Metal Fast Reactor
LWR	Light-Water (fission) Reactor
$L_{\text{TUB}}(\text{m})$	Total tube length
M	Blanket fission power multiplication, $k_{\text{eff}}/(1 - k_{\text{eff}})$
$M_{\text{BM}}(\text{tonne})$	Mass of beam-bending magnet
$M_{\text{TAR}}(\text{tonne})$	Mass of target
$M_{\text{FS}}(\text{kg}/\text{s})$	Fuel-salt mass flow rate
$M_{\text{Pu}}(\text{kg})$	Mass of plutonium to be destroyed
MBIV	Main Beam(let) Isolation Valve
MHR	Modular Helium-cooled Reactor
MOD	MODerator
MPE	Miscellaneous Plant Equipment
MS	Molten Salt
MSBE	Molten-Salt Breeder Experiment
MSBR	Molten-Salt Breeder Reactor
MSRE	Molten-Salt Reactor Experiment
MSIV	Main Steam Isolation Valve
N_A	Avagadro's number, 6.0249×10^{26} entites/mole
N_{ABC}	Number of accelerator units
N_{BLK}	Number of target-blanket modules per accelerator unit
N_{INJ}	Number of injectors
N_{TUB}	Number of tubes
O&M	Operations and Maintenance

$P^*(MW)$	Beam efficiency parameter, $E_B^0 I^*$
$P_{AUX}(MWe)$	Auxiliary (non-accelerator) plant power
$P_B(MW)$	Beam power
$P_c(MWe)$	Recirculating power, $P_{EA} + P_{AUX}$
$P_E(MWe)$	Net-electric power
$P_{EA}(MWe)$	Electrical power to accelerator
$P_{ET}(MWe)$	Gross or total electrical power
$P_F(MW)$	Fission power
$P_{TH}(MW)$	Thermal power to thermal-to-electric conversion, $\sim P_F$
$P_\Omega(MW)$	Resistive power to RF cavity wall
PHT	Primary Heat Transport
POD	Point Of Departure
ppb	protons per bunch
P_f	Plant availability factor
$p'(GeV)$	Beam momentum, pc/e
$r_B(m)$	Beam radius
$R_{TAR}(m)$	Target radius
$R_j(m)$	Radius of j^{th} system
$R_s(M\Omega/m)$	CCL shunt resistance
R&D	Research and Development
RF	RadioFrequency
RFL	ReFLector
RFP	RF Power
RFQ	RF Quadrupole
RT	Room Temperature
RTC	Reactivity Temperature Coefficient
RPE	Reactor Plant Equipment
SAF	SAFety
SCS	SuperCritical Steam
SG	Steam Generator
SHT	Secondary Heat Transport
SL	Steam Line
SLD	SHieLding
SLDA	Accelerator SHieLding
SP	Space Power
SR	Steam Reheater
$T_{LIF}(yr)$	Chronological time during which plutonium is disposed
TAR	TARget
TBA	Target-Blanket Assembly
TPE	Tu:rbine Plant Equipment
TUN	TUNnel
UTS	Ultimate Tensile Strength
$v_{FS}(m/s)$	Fuel-salt flow velocity
$V_j(m^3)$	Volume of j^{th} system
VSL	VeSseL
WIN	WINdow
WG	RF WaveGuide

$Y(n/p)$	Net target neutron yield
YS (MPa)	Yield Strength
$y(\text{MeV}/n)$	Target yield fitting parameter
$z(\text{m})$	Axial position
α_j	Bending magnet parameters
β	Parameter, $(E_p/v)/(E_B/Y)$
$\delta(\text{m})$	Conductor radius
$\Delta F(\text{MJ}/\text{mole})$	Free-energy change
ϵ	Recirculating power fraction, $(P_{\text{AUX}} + P_{\text{EA}})/P_{\text{ET}}$
ϵ_{ACC}	Accelerator power fraction, $P_{\text{EA}}/P_{\text{ET}}$
ϵ_{AUX}	Auxiliary (non-accelerator) power fraction, $P_{\text{AUX}}/P_{\text{ET}}$
$\eta(\text{ohm}/\text{m})$	Resistivity of beaming magnet windings
η_{A}	Accelerator "wall-plug" efficiency
η_{B}	Cavity RF \rightarrow beam efficiency
η_{DC}	AC \rightarrow DC conversion efficiency
η_{RF}	DC \rightarrow RF conversion efficiency
η_{VG}	RF \rightarrow cavity RF transport efficiency
η_{p}	Net plant efficiency, $\eta_{\text{TH}}(1 - \epsilon) = P_{\text{E}}/P_{\text{TH}}$
η_{TH}	Thermal-to-electric conversion efficiency
ϕ	phase angle between RF and proton beam bunch
ν	neutrons released per fission
$\rho_j(\text{kg}/\text{m}^3)$	density of j^{th} component
$\mu_0(\text{h}/\text{m})$	permeability of free space, $4\pi \times 10^{-7} \text{ h}/\text{m}$

Table I Summary of Benefits and Discriminating Features of a Driven (Subcritical, $k_{\text{eff}} < 1$) Fluid-Fuel (FF) System for Accelerator-Based Conversion (ABC) of Global Plutonium Inventories^{3,9}

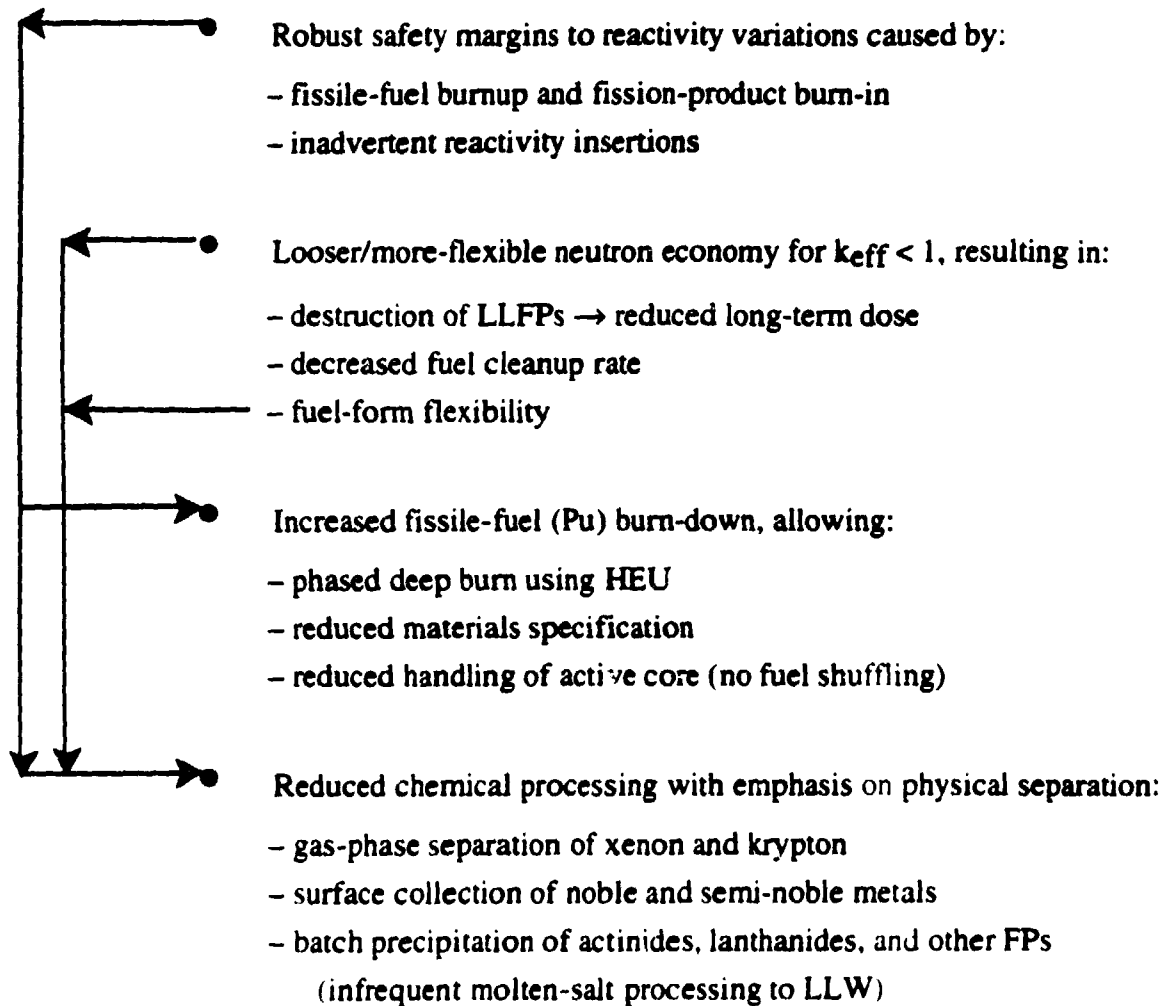

⇒ **SAFER, CLEANER, MORE-FLEXIBLE PROCESS WITH DEEP BURN AND REDUCED "DEEP DOSE" TO FUTURE POPULATIONS**

Table II "Top-Level" Subsystem Breakdown for Molten-Salt ABC

<ul style="list-style-type: none"> • Site, Buildings, and Structures <ul style="list-style-type: none"> - Site - Accelerator Tunnel (TUN) - Containment Systems (CS) <ul style="list-style-type: none"> - Containment Dome Atmospheric Control - Containment Penetrations (incl. MSIVs) - Cell Containment Structure - Cell Atmosphere Control^(k) - Cell Liner (Thermal) Shield and Cooling - Beam-Tube Isolation Valve (BTTV) - Other Structures 	CONTAINMENT
<ul style="list-style-type: none"> • Accelerator Systems ACC <ul style="list-style-type: none"> - Ion Source (IS) - Radio-Frequency Quadrupole (RFQ) - Drift-Tube Linac (DTL) - Bridge-Coupled Drift-Tube Linac (BCDTL) - Couple-Cavity Linac (CCL) - High-Energy Beam Transport (HEBT) - Window (WIN) - Tunnel (TUN) - Shield (SLDA) <ul style="list-style-type: none"> -- Main Accelerator Structure -- HEBT/TAR-BLK - Accelerator Power Systems <ul style="list-style-type: none"> -- Power Conditioning (POWAE) -- RF Power (RFP) -- RF Power Delivery (WG) -- Thermal Power Discharge (POWAT) - I&C 	ACCELERATOR EQUIPMENT
<ul style="list-style-type: none"> • Target (TAR) <ul style="list-style-type: none"> - Window (WIN) - Spallator/Coolant^(a) - Structure/Decoupler^(b) - High-Energy Neutron Shield - Gas Annulus Cooling/Monitoring Systems - I&C 	TARGET
<ul style="list-style-type: none"> • Core (COR) <ul style="list-style-type: none"> - Target/Blanket (BLK) Decoupler - Blanket/Coolant - Moderator (MOD) - Reflector (RFL) - Vessel/Structure (VSL) - Control/Shutdown Rods (CR) - Shielding (SLD) - I&C • Primary (Fuel-Salt) Heat Transport (PHT) <ul style="list-style-type: none"> - Primary System Piping - Primary Pumps - Intermediate (Primary) Heat Exchanger (IHX) - I&C • Auxiliary Core Support Systems (CSS) <ul style="list-style-type: none"> - Fuel-Salt Drain Tank(s) - Dump Tanks - Freeze Valves - Afterheat Coolers - Drain-Tank Cooling System - Storage-Tank Cooling System - I&C 	PRIMARY SYSTEMS

Table II "Top-Level" Subsystem Breakdown for Molten-Salt ABC (Cont-1)

<ul style="list-style-type: none"> • Chemical Plant Equipment (CPE)^(c) <ul style="list-style-type: none"> - Offgas Control - Fission Product Plating, Particulates, and Smoke Control^(d) - Tritium Control - Molten-Salt Chemistry (Redox) Control - Fuel Loading - Fuel-Salt Cleanup System^(e) - Coolant-Salt Cleanup System^(e) - Waste Output Preparation/Staging - I&C^(f) 	CHEMICAL PLANT EQUIPMENT	
<ul style="list-style-type: none"> • Secondary (Coolant-Salt) Heat Transport (SHT) <ul style="list-style-type: none"> - Coolant Pipes - Secondary Pumps - Steam Generator (SG) - Coolant-Salt Heaters^(g) - Secondary-Salt Drain Tank - SG Rupture Protection^(h) - I&C 	HEAT REMOVAL	BALANCE OF PLANT
<ul style="list-style-type: none"> • Balance of Plant (BOP) <ul style="list-style-type: none"> - Steam Drum⁽ⁱ⁾ - Turbine Plant Equipment (TPE) - Electric Plant Equipment (EPE) - Miscellaneous Plant Equipment (MPE) - I&C^(j) 		
<ul style="list-style-type: none"> • Central Control Systems (CCS) <ul style="list-style-type: none"> - Plant Integration, Status, and Control - Control Room(s) - Waste Management - Environmental Control 	I&C	
<ul style="list-style-type: none"> • Cell Access/Maintenance^(k) <ul style="list-style-type: none"> - Target (thimble) Replacement - Moderator Replacement - Reflector Replacement - Core Vessel Replacement - Primary-Pump Replacement - Piping Replacement - IHX Replacement - SG Replacement 	O&M	

Table II "Top-Level" Subsystem Breakdown for Molten-Salt ABC (Cont-2)

- (a) Assumed here to be one in the same (*e.g.*, molten lead).
- (b) Including target "thimb' '.
- (c) As presently envisaged, the CPE would be a loose federation of systems designed to deal with:
 - collection and trapping of volatile fission products (~25%).
 - control, monitoring, and eventual removal of fission products that plate onto cooler, post-IHX surfaces (~25%).
 - tritium control and collection prior to escape into the secondary coolant system and beyond.
 - any chemical shimming needed to assure the molten-salt solubility of the remaining 50% of the fission products, as well as corrosion control throughout the PHT system; removal of a part of this remaining 50% of fission products by a combination of physical and chemical means remains to be specified.
 - fuel preparation and loading into the PHT system.
 - all on-line analytical chemistry and related diagnostics control the PHT and TAR/BLK systems.
- (d) May also be part of offgas control system.
- (e) Water removal, oxide removal, impurity removal (NaBF_4 , *etc.*).
- (f) Including on-line chemical analysis.
- (g) Trace heaters used in steam cell, instead of oven-type heaters.
- (h) Rupture-disc, blowdown diversion systems, *etc.* in event of SG rupture.
- (i) Turbine must be capable of efficient operation with less than full steam flow, (*i.e.*, when one of the N_{BLK} modules is inoperable).
- (j) Controls necessary to allow a trip of one module without shutdown of entire plant, may be complicated).
- (k) Applies primarily to Reactor Cell; similar requirements anticipated for other cells [(*e.g.*, CPE (if any), SG, tanks, *etc.*)].

Table III. Specified and Derived ABC Parameters from Plant Layout Study

Overall Plant ^(a)	
Mass of weapons plutonium to be disposed, M_{Pu} (tonne) ^(b)	50.
Thermal energy value of plutonium to be disposed, GWyr ^(b)	128.
Time allowed to demonstrate disposition technology, yr	20.
Time to dispose, T_{LIF} (yr)	20.
Annual availability or plant factor, p_f	0.75
Thermal-to-electric conversion efficiency, η_{TH}	0.444
Total electrical power generation, $N_{ABC} P_{ET}$ (MWe)	3,789.
Number of ABC units, N_{ABC}	3
Total electrical power generation per ABC unit, P_{ET} (MWe)	1,263.
Total thermal power generation per ABC unit, P_{TH} (MW)	2,844.
Number of Target/Blankets per ABC unit, N_{BLK}	4
Thermal power per Target/Blanket, P_{TH}/N_{BLK} (MW)	711.
Recirculating power fraction, $\epsilon = P_c/P_{ET}$	0.15
• ACC recirculating power fraction, $\epsilon_{ACC} = P_{EA}/P_{ET}$	0.12
• BOP recirculating power fraction, $\epsilon_{AUX} = P_{AUX}/P_{ET}$	0.03
Net electrical power per ABC unit, P_E (MWe) = $(1 - \epsilon)P_{ET}$	1,074.
Recirculated power, P_c (MWe) = ϵP_{ET}	189.
• ACC power, P_{EA} (MWe) = $\epsilon_{ACC} P_{ET}$	152.
• BOP power, P_{AUX} (MWe) = $\epsilon_{AUX} P_{ET}$	38.
Accelerator "wall-plug" → beam efficiency, η_A	0.45
Beam power, P_B (MW) = $\eta_A P_{EA}$	68.4.
Beam power per Target/Blanket assembly, P_B (MW)/ N_{BLK}	17.1
Blanket multiplication	
• $M = k_{eff}/(1 - k_{eff}) = (P_F/P_B)/\beta$ ^(c)	24.2
• k_{eff}	0.96
Beam current	
• Accelerator I_B (A) ^(d)	0.086
• Target, I_B/N_{BLK} (A)	0.021

Table III Specified and Derived ABC Parameters from Plant Layout Study (Cont.-1)

Accelerator	
Number of injectors, N_{INJ}	1
Length of front-end, $L_{FE}(m)$	~20.
Efficiencies, $\eta_A = \eta_{DC} \eta_{RF} \eta_{WG} \eta_B$	0.45
• AC → DC, η_{DC}	0.90
• DC → RF, η_{RF}	0.65
• RF → cavity, η_{WG}	0.98
• cavity → beam, $\eta_B = 1/(1 + I^*/I_B)$	0.78
CCL parameters	
• “Real-estate” gradient, $G(MV/m)$	1.0
• Shunt resistance, $R_s(M\Omega/m)$	55.
• Cosine of RF-bunch phase angle, $\cos\phi$	0.77
• Frequency, $f(Mhz)$	700.
• Efficiency factor, $I^*(A) = f_D G/R_s/\cos\phi$	0.024
• Duty factor, f_D	0.10
Accelerator length, $L_{ACC}(m)$	850.
High-Energy Beam-Transport length, $L_{HEBT}(m)$	100.(?)
Tunnel volume, $V_{TUN}(m^3)$	---
Support buildings	---
• Area, m^2	---
• Volume, m^3	---
Beam Entrance (Bend and Expander)^(e)	
Beam-tube radius, $a(m)$	0.10
Conductor radius, $\delta(m)$	0.07
Beam radius of curvature, $R(m)$	2.83
Magnetic field, $B(T)$	1.58
Conductor current, $I(MA/conductor)$	0.37
Resistive power losses, $P_{\Omega}(MW)$	1.50
Mass of conductor, $M_{BM}(tonne)$	1.10
Expander length, $L_{EXP}(m)$	10.

Table III Specified and Derived ABC Parameters from Plant Layout Study (Cont.-2)

Primary System	
Target nominal dimensions	
• Diameter, $D_{TAR}(m)$	0.75
• Height, $H_{TAR}(m)$	0.6
Core^(e) nominal dimensions	
• Diameter, $D_{COR}(m)$	3.5
• Height, $H_{COR}(m)$	3.5
• Volume, $V_{BLK}(m^3)$	33
Average fuel-salt fraction in core, f_{FS}	0.13
Core power densities	
• Average core, $PD(MW/m^3) = P_{TH}/N_{BLK}/V_{BLK}$	22.2
• Fuel salt, $PD/f_{MS}(MW/m^3)$	171
Total fuel salt volume, $V_{MS}(m^3)$	12.5
Fuel-salt temperatures (K)	
• Core inlet/IHX outlet	???
• Core outlet/IHX inlet	???
Fuel-salt flow rate, $\dot{M}_{FS}(kg/s)$???
Fuel-salt pump (nominal) dimensions	
• Diameter, $D_{FSP}(m)$	2.0
• Height, $H_{FSP}(m)$	7.5
IHX (nominal) dimensions	
• Diameter, $D_{IHX}(m)$	1.75
• Height, $H_{IHX}(m)$	6.55
Fuel salt (residence) fractions	
• Core	0.34
• IHX	0.32
• Pumps	0.16
• Other	0.18
Loop-averaged power density, $\langle PD \rangle (MW/m^3) = P_{TH}/N_{BLK}/V_{MS}$	57.
Dump-Tank volume, $V_{DT} (m^3)$	45.
Reactor-Cell volume, $V_{PS}(m^3)$	850.

Table III Specified and Derived ABC Parameters from Plant Layout Study (Cont.-3)

Heat-Removal System	
Coolant-salt volume, $V_{CS}(m^3)$	41.
Coolant-salt pump (nominal) dimensions	
• Diameter, $D_{CSP}(m)$	2.0
• Height, $L_{CSP}(m)$	7.5
Coolant-salt flow rates	
• Steam generator, $\dot{M}_{SG}(kg/s)$???
• Steam reheater, $\dot{M}_{SR}(kg/s)$???
• IHX, $\dot{M}_{IHX}(kg/s)$???
Steam-generator (nominal) dimensions	
• Length, $L_{SG}(m)$	7.3
• Height, $H_{SG}(m)$	6.0
Coolant-salt temperatures (K)	
• SG/SR inlet	???
• SG outlet	???
• SR outlet	???
Steam-generator cell volume, $V_{SG}(m^3)$	1,800.
Steam flow rate, $\dot{M}_{SCS}(kg/s)$???
Steam pressure, $p_{SCS}(MPa)$	25.9
Steam temperature, $T_{SCS}(K)$	810.

Chemical Plant Equipment	
Annual fission product generation, $R_{FP}(kg/yr)$	1,667.
• gaseous	
– tritium	???
– noble gases	???
• noble and semi-noble metals	???
• lanthanides	???
Volume of processing equipment, $V_{CP}^j(m^3)$	
• gaseous	
– tritium	???
– noble gases	???
• noble and semi-noble metals	???
• lanthanides	???

Table III Specified and Derived ABC Parameters from Plant Layout Study (Cont.-4)

Containment Building/Envelop	
Volume of containment, $V_{CB}(m^3)$	23,000.
Specific Volume, $P_{TH}/N_{BLK}/V_{CB}(MW/m^3)$	0.031
Supercritical-steam system	
• Thermal Power, $P_{TH}(MW)$	2,833.
• Number of loops, N_{SCS}	???
• Steam-generator temperatures, $T_{in}/T_{out}(K)$???/810.
• Mass flow rate, $M_{SCS}(kg/s)$???
• Pressure, $P_{SCS}(MPa)$	24.9
Turbine Plant Equipment	
• Number, N_{TPE}	4
Turbine ratings (MWe)	
• Gross rating	???
• Net rating	316.
• Gross electric power, $P_{ET}(MWe)$	1,263.(g)
• Net overall thermal conversion efficiency, η_{TH}	0.444.
Electric Plant Equipment	
• Net electrical power, $P_E(MWe)$	1,074.
• Recirculating power fraction, ϵ	0.15
• Plant efficiency, $\eta_p = \eta_{TH}(1 - \epsilon)$	0.377

-
- (a) The parameters in this section of the table are presented in the order of determination.
- (b) Assumed total destruction (fissioning) of M_{Pu} mass of weapons plutonium; burnup >90% however, will require use of highly enriched uranium (HEU) near end of life (EOL), increased accelerator power (decreased k_{eff}) or both.
- (c) $\beta = [E_F/v]/[y/(1 - E_B^0/E_B)]$, where $y \approx 30$ MeV/n and $E_B^0 \approx 200$ MeV/p are fitting parameters to the target neutron yield relationship, $Y(n/p) = (E_B - E_B^0)/y$; $E_F = 200$ MeV/fission; and $v = 2.9$ n/fission. For a beam energy $E_B = 800$ MeV/p, $\beta = 1.72$.
- (d) Base on a beam energy $E_B = 800$ MeV/p.
- (e) Appendix F
- (f) Target thimble, fuel salt, graphite moderator, graphite reflector, control/shutdown rods, structure, reactor vessel.
- (g) A single 285-MWe turbine would be used for each Target-blanket module; four of these less the recirculating power would provide $P_E \approx 967$ MWe to the grid; most of the BOP sizing assumed the use of a single turbine with gross capacity equal to 315 MWe.

Appendix A. Subsystem Design Bases and Equipment Scaling

A.1. Introduction

This appendix documents all calculational and design bases used to define a molten-salt-fueled ABC. Additionally, all key assumptions and groundrules are summarized. Lastly, design details and procedures not reported in the body of the report are elaborated in this appendix. In terms of developing an indepth understanding for use in a future, more-detailed conceptual design of ABC, this appendix serves both as a focal point and a resource. Generally, the ABC Plant Layout Study emphasizes the "reactor" aspects and for this reason draws heavily on earlier work performed at ORNL as part of the Molten Salt Breeder Reactor (MSBR) Program^{10,11,46,47}. The Accelerator Equipment design is elaborated only to an extent needed to fulfill the goals of a plant layout study and the input such a study has to the development of an overall R&D plan for ABC⁹.

The main body of this appendix consists of descriptions of the important equipment and piping systems for ABC. For each piece of equipment, the basis for the design is given along with important assumptions and caveats. Any scaling necessary for adaptation to the ABC is quantitatively described. The level of detail provided is not uniform for all systems, however; some systems are described in great detail while others are not. The determinants for this variability is not the specific importance of a given subsystem as much as the availability of information. Most of the information for this ABC design is taken from the MSBR design, as is described in Ref. 10. Areas in which detail was not available from the MSBR design are not described in great detail. The only exception to this is the Accelerator Equipment and Target system, which have be subject to only preconceptual designs and are described only superficially in this appendix.

This appendix arranged into five major sections. The history of the molten-salt reactor concept is given under Background in Sec. A.2. This background is followed by a discussion in Sec. A.3. of key assumptions used in the development of this concept. The Individual System Descriptions Sec. A.4. is divided according to eight subsystems: Accelerator; Target; Primary System; Balance of Plant; Chemical Processing; Operations and Maintenance (O&M); Instrumentation and Control (I&C); and Safety Systems. Flow calculations and the resulting mass flow rates and velocities required to size key subsystems are described in Sec. A.5. Finally, outstanding technical issues are described in Sec. A.6., which is divided into materials, design, and miscellaneous categories. A synopsis of these issues is given in the Sec. I., Executive Summary.

A.2. Background

The goal of this design effort and the associated research is to combine the features of a molten-salt breeder reactor with those of an accelerator. The resulting ABC system is to fission surplus weapon plutonium to high burnup while minimizing the production of byproduct wastes. The molten-salt reactor concept was studied extensively from the 1950s to the 1970s at ORNL^{10,11,45,46}. This effort was originally intended to produce a nuclear power plant for aircraft propulsion, but was later redirected toward the development of a thermal breeder based on the ²³²Th-²³³U fuel cycle. Although a full-scale breeder was never built, two smaller experimental reactors were constructed and operated.¹¹

The first reactor was the Aircraft Reactor Experiment (ARE).⁴⁸ The ARE was a simple arrangement with a primary goal being a feasibility demonstration. Operated for approximately 221 hours in November, 1954, the favorable results led to the construction and operation of the Molten Salt Reactor Experiment (MSRE). The MSRE was larger and was designed for extended operation. It operated at power levels up to 7.4 MW from 1965-1969.⁴⁶ The MSBR design^{10,11} was based to a large extent on the design and operation of the MSRE and on the subsequent development work that was carried out through the mid-1970s.

The accelerator design is taken from the Accelerator Production of Tritium (APT) design.⁴⁹ Both the ABC and the APT use linear accelerators (Linacs) to accelerate protons to high energy. The accelerator to be used with the ABC system delivers less beam power than the APT accelerator (~70 MW *versus* 200 MW). Experience exists with accelerators of this type^{16,17,50} as experimental machines, but not as part of a high-power, high-availability production facility. Scaleup and design improvements to increase accelerator availability will be necessary for the implementation of the ABC system.

While the design described in the ABC Plant Layout Study is intended to be both self-consistent and conceptually feasible, this design is far from optimized. Conservatism included in the design should increase the probability of a successful implementation of the ABC approach to plutonium disposition. Scaling and extrapolation was necessary, however, to obtain capacities and dimensions of the major equipment, as applied to ABC conditions. The resources available for performing this work were not sufficient to allow original design work to proceed. The existence of the significant knowledge base developed as part of the MSBR program, as well as the documentation and maintenance of this knowledge base over the intervening years, was of immense benefit to the ABC Plant Layout Study.

A.3. Assumptions

Inherent in any pre-conceptual design are numerous and essential assumptions and groundrules. This section identifies these assumptions and groundrules. When appropriate, the basis for each is given.

The primary groundrule for the ABC Plant Layout Study is established by the intended project goal; to dispose of $M_{Pu} \approx 50$ tonne of weapons plutonium. Assuming a twenty year development and construction period, this goal allows $T_{LIF} = 30$ yr for plutonium destruction. A more conservative approach has been adopted, however, wherein plutonium destruction is to be performed over a twenty-year period to allow for additional time for development and/or deployment, albeit, higher capacity (rate) systems will be required. By specifying M_{Pu} and T_{LIF} , the thermal-power requirement results. Assuming each ^{239}Pu fission yields on average $E_F = 200$ MeV, the total thermal power produced by the fissioning of fifty tonnes of ^{239}Pu is 4.04×10^{18} J (128 GWt yr). Assuming a twenty year burn time, with an average lifetime capacity factor of $p_f = 0.75$, the thermal capacity required for disposing of the fifty metric tons of plutonium is 8,530 MWt. For $N_{ABC} = 3$ ABC units having N_{BLK} Target-Blanket/Power-Conversion modules per ABC accelerator unit, each module will develop and convert a thermal power of $8,530/N_{ABC}/N_{BLK} = 711$ MW. This power is consistent with the restrictions imposed by the Target power density and neutron-generation efficiency (Appendix C). Generally the Core size (thermal power)

is limited by the desire to maintain the neutronic worth of the target at a certain level. The maximum Core capacity has been estimated to be as high as $P_{TH} = 2,000$ MWt, but this limit is not well documented. Most of the target designs performed to date have limited the Core to 600 MWt based on safety (afterheat) consideration. Although economic benefits would be expected to accompany an increase in module size (and concomitant decrease in the number of modules), these benefits have not been quantified for the ABC and, therefore, have not been shown to counterbalance the operational flexibility provided by the smaller modules. For an accelerator-driven power plant based on the ^{232}Th - ^{233}U fuel cycle, however, significant economic benefits accrue from minimizing N_{BLK} and maximizing P_{TH} ¹⁵.

The net plant thermal efficiency is taken to be the same as that of the MSBR ($\eta_{TH} = 0.444$), because of similarities in the two systems. This conversion efficiency yields a gross electrical output of $P_{ET}/N_{BLK} = 316$ MWe for each Target-Blanket module and a combined total of $P_{ET} = 1,263$ MWe for each of the three ABC systems. For the remainder of this appendix and most of the report, a "module" is defined as a 711 MWt/316 MWe combination of Target, Blanket, and Power-Conversion equipment. A "system" refers to the combination of $N_{BLK} = 4$ modules along with a single, supporting linear accelerator. The net thermal efficiency quoted above for the MSBR design includes the effects of plant load, both electrical and mechanical, for the reactor and associated systems. The accelerator and the associated power requirements represents a new element in the overall plant power balance that must be accounted before the net power delivered to the grid, $P_E = P_{ET}(1 - \epsilon)$, can be estimated, where $\epsilon = \epsilon_{ACC} + \epsilon_{AUX}$, ϵ_{AUX} is the fraction of P_{ET} needed to meet auxiliary power demands associated with the Accelerator Equipment plant, and ϵ_{ACC} is the fraction of P_{ET} recirculated to the Accelerator Equipment to create the energetic proton beam. Conservatively taking $\epsilon_{AUX} = 0.02$ and $\epsilon_{ACC} = 0.12$, which corresponds to an accelerator "wall-plug" power of $P_{EA} = 152$ MW, a nominal power delivered for sale to the electrical grid from each of the $N_{ABC} = 3$ ABC units would be $P_E = 1,074$ MWe. For an accelerator "wall-plug" efficiency of $\eta_A \sim 0.45$ (Appendix B), the beam power per module would be $P_{EA}/\eta_A/N_{BLK} = 17$ MW. These sample parameters are summarized on Table III.

Another important groundrule adopted for the ABC Plant Layout Study deals the minimization of the technical extrapolation from MSBR to ABC. Departures from the Ref.-10 MSBR design are proposed only to accommodate the accelerator beam and the target, to upgrade the design for modern safety requirements, and to incorporate molten-salt experience gained after the completion of the reference MSBR design¹⁰. Although the overall layout and equipment details have changed, the ABC design retains the essential elements of the MSBR design, thereby providing a firm foundation on which to develop, build, and (ultimately) operate the ABC.

Many other assumptions were evoked in the development of the ABC plant layout. For the most part, these assumptions are associated with individual systems or components and, therefore, are discussed in the relevant component descriptions given in subsequent sections of this appendix.